

► Lamps FL-70 SERIES

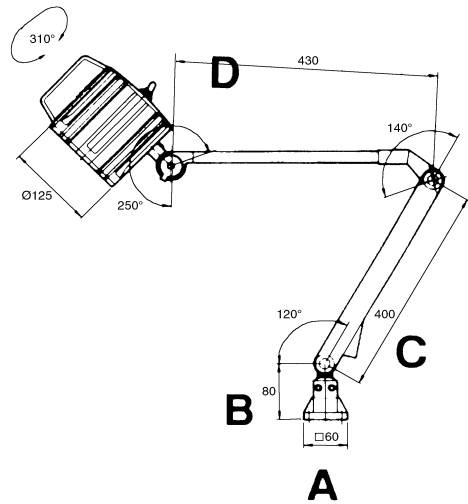

FEATURES

Totally enclosed lighting head provides good protection against explosions, dust, coolant and lubricants.

Uses efficient Quartz Halogen bulb, great light output, soft illuminating without irritating the eyes.

Fitted with electronic transformer (FL-70NT SERIES) or coil transformer (FL-70NT SERIES) for high power transmission.

MODEL	VOLT	IP	WATT (BULB)	DIMENSION (MM)			
				A	B	C	D
FL-70L	12V or 24V	65	50W	□60	80	400	430
FL-70M	12V or 24V	65	55W	□60	80	200	250
FL-70S	12V or 24V	65	70W 75W	□60	105		
FL-70NTL	110V	65	50W	□70	115	400	430
FL-70NTNTM	or 220V	65	50W	□70	115	200	250
FL-70NTS	or 380V or 415V	65	50W	□70	120		