

▶ TR Type ELECTRIC PUMPS - TRANSFER RANGE



MECHANICAL FEATURES

Pump BodyCast Iron
ImpellerBronze

MOTOR CHARACTERISTICS

ProtectionIP55
InsulationCL. F
VoltageEurovoltage 3PH & 1PH
Frequency50Hz

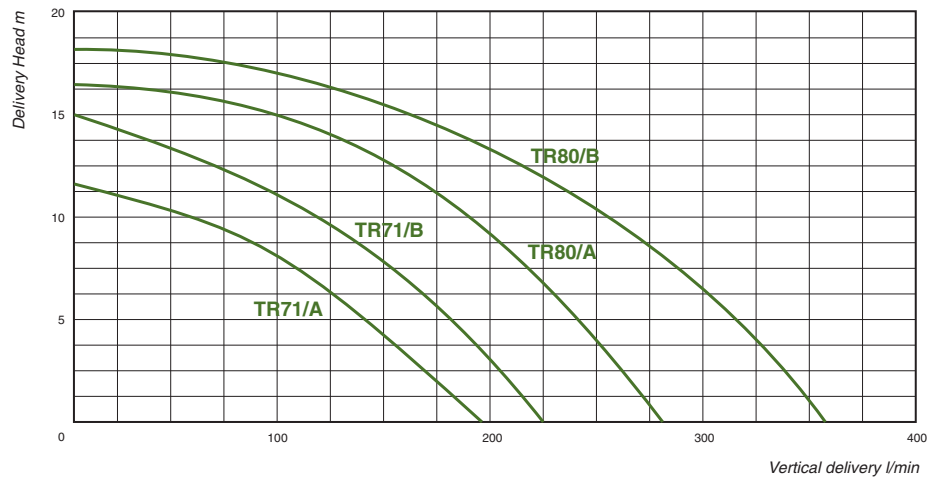
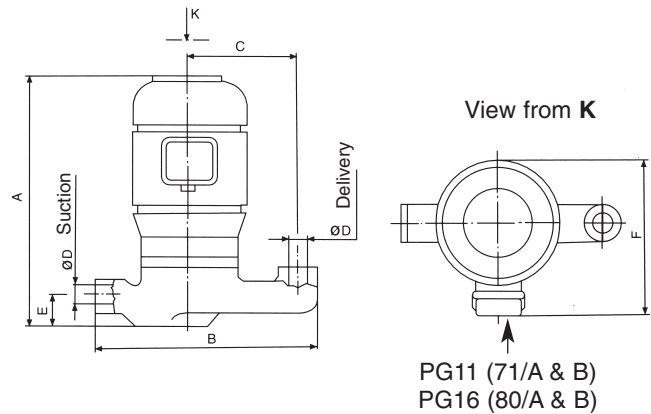

| TYPE | KW Absorbed | PG | HP | AMPS 400 V | A mm | B mm | C mm | ØD | E mm | F mm | WEIGHT kg |
|---------|-------------|----|------|------------|------|------|------|--------|------|------|-----------|
| TR 71/A | 0.53 | 11 | 0.71 | 1.4 | 320 | 290 | 130 | 1" BSP | 40 | 200 | 12.10 |
| TR 71/B | 0.78 | 11 | 1.04 | 1.9 | 320 | 290 | 130 | 1" BSP | 40 | 200 | 13.00 |
| TR 80/A | 1.15 | 16 | 1.54 | 1.9 | 370 | 290 | 130 | 1" BSP | 40 | 220 | 13.90 |
| TR 80/B | 1.7 | 16 | 2.27 | 2.8 | 370 | 290 | 130 | 1" BSP | 40 | 220 | 14.70 |

| TYPE | PUMP BODY | KW Absorbed | CONNECT BSP | HEAD METRES | | | | | | | | | | | | |
|---------|-----------|-------------|-------------|-------------|-----|-----|-----|-----|-----|-----|-----|----|----|----|----|--|
| | | | | 2 | 4 | 6 | 8 | 10 | 12 | 14 | 16 | 18 | 20 | 22 | 24 | |
| TR 71/A | 2 | 0.53 | 1" | 125 | 110 | 95 | 80 | 65 | 30 | 3 | | | | | | |
| TR 71/B | 2 | 0.78 | 1" | 140 | 132 | 124 | 116 | 108 | 70 | 35 | 5 | | | | | |
| TR 80/A | 2 | 1.15 | 1" | 155 | 148 | 142 | 136 | 130 | 115 | 100 | 85 | 70 | 30 | 10 | | |
| TR 80/B | 2 | 1.7 | 1" | 180 | 175 | 170 | 160 | 150 | 140 | 120 | 100 | 80 | 60 | 25 | 10 | |



6 Collins Road Heathcote Industrial Estate Warwick CV34 6TJ U.K.
telephone: 01926 451744 **fax:** 01926 451284
e-mail: sales@pumps-equip.co.uk **web:** www.pumps-equip.co.uk