

Coolant Cleaner

MINI-QUICKSEP® MK II SILVERLINE

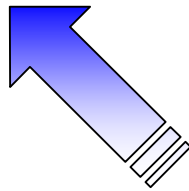
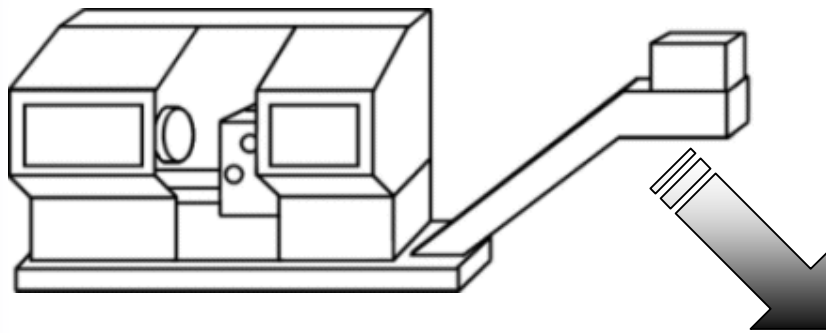

Aerates and separates oil and surface chips (sludge) from emulsions as well as from:

- Wash baths
- Hardening baths
- Degreasing baths
- Water
- Etc.

Available in 2 sizes: 70 l/h and 120 l/h

The consequent application of different physical laws in the compact coolant cleaner of the type **MINI-QUICKSEP MK II Silverline** as well as the optimal combination of the suction float and the pump are responsible for the very efficient cleaning capacity of these units. The unwanted and free oils are efficiently separated from all contaminated fluids such as metal cutting emulsions, wash baths, hardening baths etc. At the same time the emulsion is being aerated. The clean medium from which the unwanted oils have been separated flows back to the treatment tank by gravity.

The separation performance lies at over 98% when demulsifying fluids are used. Except for the pump and the motor there are no moving parts within the coolant cleaner MINI-QUICKSEP. Due to this fact maintenance costs are reduced to a minimum and it is only necessary to rinse out the unit once or twice per year.

The standard execution of the compact coolant cleaner **MINI-QUICKSEP MK II Silverline** is delivered completely with oil tank with overflow protection, hydraulic dry run protection for the pump, feed and return tubes as well as a float. Different accessories such as various types of floats (also for a fixed assembly into a tank) as well as pre-filters, containers for the tubes and mobile carriages with larger oil tanks of 25 l content are available. All units are built for ambient temperature. Special reinforced units for temperatures up to 75°C are also available.

Technical data for stationary unit type MINI-QUICKSEP :

		MINI-70	MINI-120
Dimensions:	width	500 mm	530 mm
	depth	300 mm	410 mm
	height	820 mm	1055 mm
Volume:		14 litres	28 litres
Weight (empty):		27 kg	34 kg
Flow capacity nominal:		approx. 150 l/h	approx. 180 l/h
Flow capacity effective:		approx. 70 l/h	approx. 120 l/h
Drive:	220/240 Volt,	0,18 KW	0,25 KW
	or 3 x 440 Volt	0,25 KW	0,3 KW
Option	with oil tank of 25 l volume, with safety tub, mobile		



MINI-QUICKSEP MK II 120
with 10 l oil tank.

Suction floats:

A range of various suction floats with magnetic base or units for fixed assembly with tanks are available ex stock. Special executions to customer specification can be manufactured on short term.

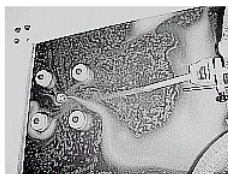

MINI-QUICKSEP MK II
with additional safety tank.

Accessories:

Pre filter:

Suitable for the separation of floating metal chips and other solid contamination. Including filter bag with mesh of 420 my. As option with magnetic pre separation.

