

# COOLTOOL CT70-2

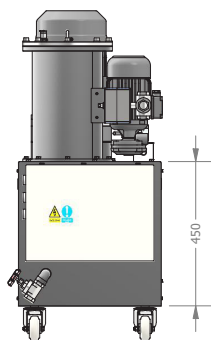

## CT-70 Footprint

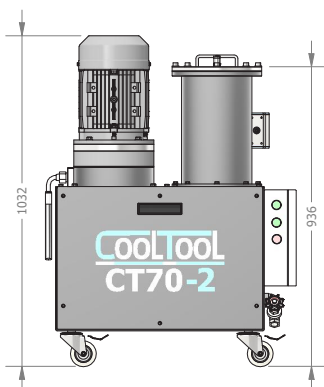
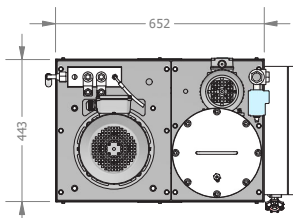

- Inlet Pressure - Force-fed @ 5 Bar
- Maximum Pressure - 70 Bar
- Maximum Flow - 30 Litres
- RPM - 1420
- Voltage - 200V
- Power - 16 Amps
- Kilowatts - 4KW
- Single Filter - 10 µm (micron) washable
- Outlets - 1@ 70 Bar  
1@ 50 Bar (Optional)  
1@ 20 Bar (Optional)
- Integrated Control Panel -
- Integral Filter Feed Pump -
- **Optional 4 Bar Wash Gun -**



DESIGNERS OF HIGH-PRESSURE SYSTEMS  
www.pumps-equip.co.uk

Sales@pumps-equip.co.uk (01926) 451744