

Immersion pumps

Type AP 100A - 112A-B



Usages:

These pumps are suitable for transferring liquids containing impurities measuring up to 2 mm. The hydraulic components, namely the cast-iron impeller and scroll and the steel pump body, allow the pumps to be used with water, emulsions and oily substances in general with a maximum viscosity of 3° Engler (21 CST). The temperature of the liquid must not exceed 90° C.

They are usually used on:

- **Machine tools** (milling machines-lathes-work centres)
- **Glass processing machines**
- **Surface treatment systems**
- **Filtration systems**

They should usually be installed at about 6 – 7 cm. from the base of a tank, with a capacity in proportion to the flow rate. It is important to check that the maximum level of the liquid in the tank always remains 3 – 4 cm. lower than the flange (see figure).

In cases where the liquid is particularly dirty, the user is recommended to construct the tank in compartments to allow the dirt to deposit before it is stirred up by the pump.

For other usages you are advised to consult our technical office.

Table of dimensions and weights

TYPE	A mm	B mm	C mm	D mm	ØE mm	ØF mm	ØG mm	ØH mm	ØI mm	ØL mm	M mm	N mm	Kg.
AP 100A	700	320	380	280	240	1-1/2"	2-1/2"	300	270	13 N. 4	170	136	48
	830	450											54
	990	610											56
	1240	860											58
AP 112A	730	320	410	280	240	1-1/2"	2-1/2"	300	270	13 N. 4	170	136	59
	860	450											65
	1020	610											67
	1270	860											69
AP 112B	730	320	410	320	240	2"	2-1/2"	300	270	13 N. 4	190	145	61
	860	450											67
	1020	610											69
	1270	860											71

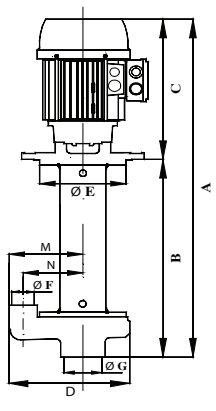

Electrical features

TYPE	KW. Input	Hz. 50		Hz. 60			
		230/400	254-290/440-500	230/400	208-230/440-460	254-277/440-480	318-346/550-600
AP 100 A	4,80	14,5/8,4	11,0/6,3	17,3/10	14,8/8,6	14,5/8,4	11,4/6,0
AP 112 A	5,50	19,2/11	14,5/8,4	23,8/13,8	19,4/11,2	19,2/11	15,2/8,7
AP 112 B	6,00	21,0/12,2	16,0/9,2	25,2/14,5	21,4/12,4	21,0/12,2	16,6/9,6

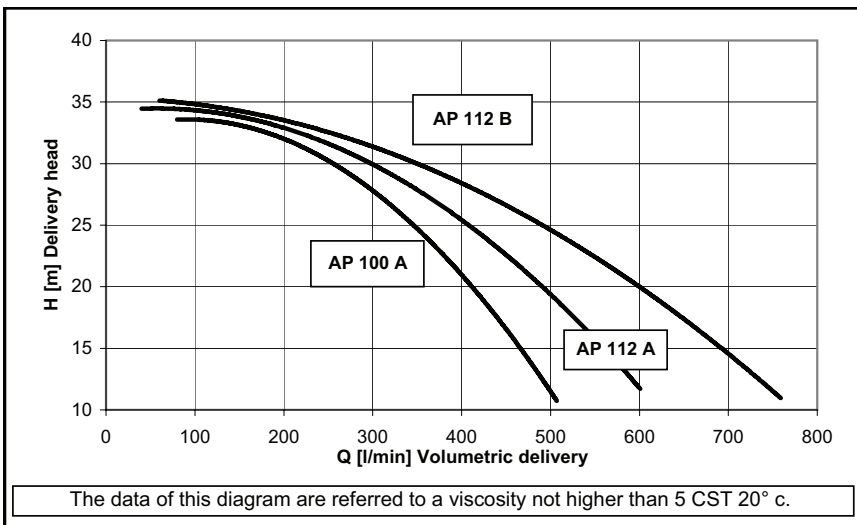
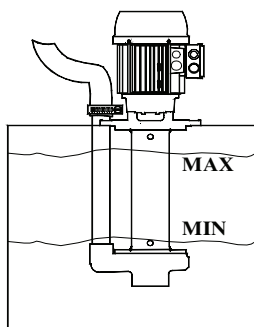
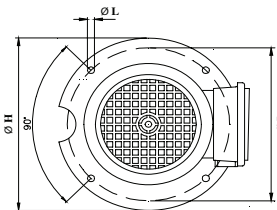

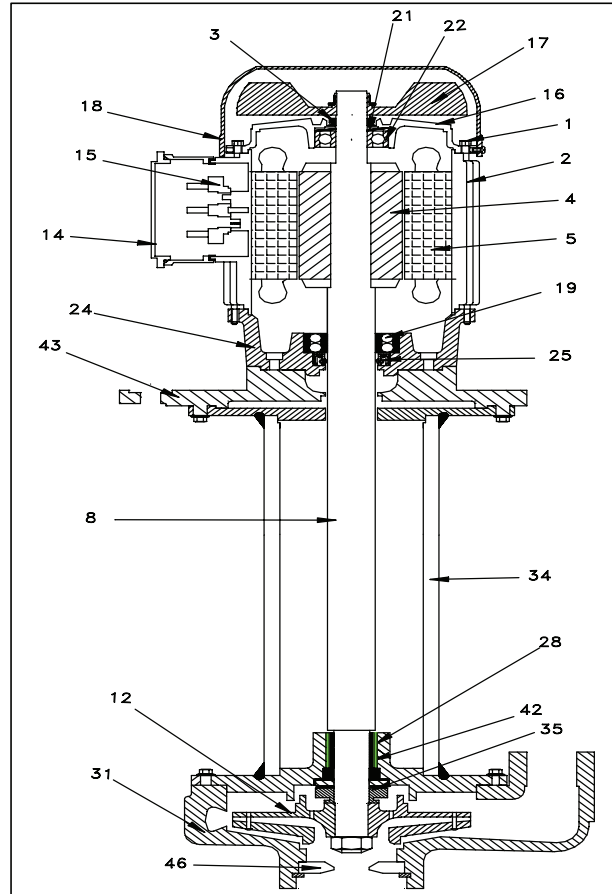

Type	AP 80 B	AP 90 A-B	AP 100 A	AP 112 A-B
Components	materials	materials	materials	materials
1 Rod	Steel	Steel	Steel	Steel
2 Frame	Aluminium	Aluminium	Aluminium	Aluminium
3 V-ring	NBR ø 20	NBR ø 25	NBR ø 30	NBR ø 30
4 Rotor				
5 Stator				
8 Shaft	Steel	Steel	Steel	Steel
12 Impeller	Cast iron G20	Cast iron G20	Cast iron G20	Cast iron G20
14 Terminal box	Nylon	Nylon	Nylon	Nylon
15 Terminal block	mm. 50x32 6P	mm. 50x32 6P	mm. 50x32 6P	mm. 56x36 6P
16 Non-drive end shield	Aluminium	Aluminium	Aluminium	Aluminium
17 Fan	Nylon	Nylon	Nylon	Nylon
18 Fan cover	Nylon	Nylon	Nylon	Nylon
19 Bearing	62206 2RS (*)	62207 2RS	62207 2RS	62207 2RS
21 Spring ring	ø 47	ø 52	ø 62	ø 62
22 Bearing	6204 ZZ	6205 ZZ	62206 2RS	62206 2RS
24 Drive end shield	Cast iron G20	Cast iron G20	Cast iron G20	Cast iron G20
28 Bronze bearing (*)	28x30x30	28x30x30	28x30x30	28x30x30
31 House impeller	Cast iron G20	Cast iron G20	Cast iron G20	Cast iron G20
34 Tube on length 450-610-800	Steel	Steel	Steel	Steel
34 Cone on length 320mm	Cast iron G20	Cast iron G20	Cast iron G20	Cast iron G20
35 Mechanical seal	ø 22 - ø 45	ø 22 - ø 45	ø 22 - ø 45	ø 22 - ø 45
42 Ring IR (*)	22x28x30	22x28x30	22x28x30	22x28x30
43 Support flange	Cast iron G20	Cast iron G20	Cast iron G20	Cast iron G20
46 Suction reduction	Nylon	Nylon only AP 90A	No	No

19 (*) On body pump length mm. 450-610-860 = 63007 2RS

28-42 (*) Only son body pump length mm. 860

