



KSQ9001:2009/ISO9001:2008

T-ROTOR OIL PUMPS

Continuous to feeding
Supplying Fuel and lubrication oil
Hydraulic composition



A-RYUNG
www.aryung.co.kr

AR2013-ATP-EK1

T-ROTOR OIL PUMPS

CONTENTS

2 Technical data

T-ROTOR pumps

8 AR1-F Series

9 AR2-FC Series

10 ATP-S Series

11 ATP-HA Series

14 ATP-H/HF Series

16 ATP-4**HVB Series

Motor T-ROTOR pumps

18 AMTP-MS/MT Series

20 AMTP-HA Series

22 AMTP-HAVBF Series

24 AMTP-HA/HAVB Series

26 AMTP-750-P4 Series

27 AMTP-320LNVB Series

28 AMTP-LN Series

30 AMTP-FAVB/HFVB Series

32 AMTP-CH Series

34 AFC Series

37 Terminal connection



Technical data

T-ROTOR Pump의 개요

- T-ROTOR 란 고정된 원주위를 미끄럼 없이 구름 접촉운동하는 하나의 원형판 내부의 일점의 궤적을 말하며 원판이 원주 밖에서 외접 구름운동을 하여 형성된 궤적을 Epi-trocho라고하며, 원주내에서 내접 구름운동을 하여 생긴 궤적을 Hypo-trocho라 한다.
- T-Rotor Pump는 이러한 Trocho Curve에 의하여 제작된 한 쌍의 내, 외접차차로 구성되어 있는 일종의 내접 Gear Pump이다.

Summary of T-ROTOR Pump

- Trochoid means a plane locus of point made by rolling contracting movement on an extension of the radius of a circle, while the circle is rolled along the fixed straight line.
- The plane locus comes out in two different trails, one is called Epi-trocho moving the gear outside trail, the other is Hypo-trocho moving the gear inside trail.

T-ROTOR Pump의 작동원리

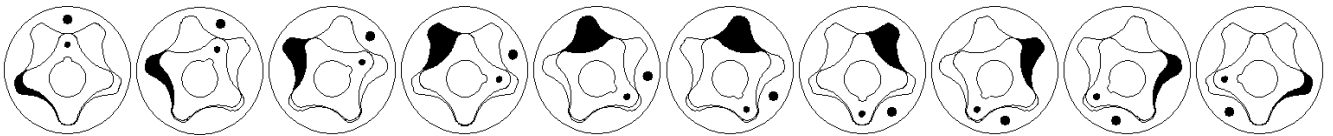

- T-ROTOR펌프는 Trochoid Curve의 원리에 의하여 제작된 한쌍의 치차가 내접 구름운동을 하면서 일정한 공간을 형성하여 흡입 토출하는 Pump이다.
- 외접차차(Out Rotor)보다 기어 잇수가 하나 적은 내접차차(h-Rotor)는 외접차차와 서로 일정한 거리만큼 편심되어 회전하여 내·외접차간에 항상 일정한 공간이 형성되고 연속적으로 공간이 크고 작아짐의 반복 운동에 따라 유체를 강제적으로 흡입, 토출하도록 설계된 Pump로서 Rotor의 운동 형태는 위 그림과 같다.

Operation Principle of pump

- T-Rotor pump is as internal gear pump in which a couple of rotors inner rolling movement along the trochoid curves forming a space from where a charging and discharging forces are produced.
- outer rotor makes rotating movement with inner rotor that has less gear than itself by one tooth and they are pivoted together so that rotate about the same axis. Above picture shows rotor movement.

T-ROTOR Pump의 특징

- 흡입압력이 높고 기계적 효율 및 용적효율이 높다.
- 내·외접차차가 Trochoid Curve에 의한 구름접촉 운동을 하므로 Gear Pump보다 상대속도가 작아 치의 마모 및 토출 맥동이 적다.
- 구조가 간단하여 분해 조립 등 수리가 용이하다. 또한 같은 용량의 Gear Pump보다 소형이며 수명길고 1회전당 토출량이 많다. Gear Pump와 같이 Crescent-Shaped Spacer가 필요치 않으며 윤활, 유압용, 이송용 등 용도가 다양하다.
- 항상 1점 접촉운동을 하므로 저속 및 고속 회전(300~3000rpm)까지 회전 범위가 넓다.

Characteristics of pump

- This pump has high suction pressure and excellent mechanical efficiency.
- The pump has simple structure, though small size, easy dismantle and assembly for overhaul and has greater discharge volume per one stroke than gear pump of the same size, also has long life.
- This needs not crescent shaped spacer like pump and it is applied lubrication, oil transfer, and hydraulic system.

T-ROTOR pumps

Technical data

■ 사용시 유의사항

• Pump의 설치장소

Pump의 설치장소는 통풍이 잘되고 온도, 습도가 적은 장소를 택하고 Pump의 위치는 Tank보다 약간 높은 곳에 설치하는 것이 좋다

• 토출량, 점도, 회전수

Pump의 토출량은 회전수에 비례하고 적정회전수는 1000-1800rpm, 점도는 40°C에서 20~1000cSt범위가 적정하다.

또한 같은 규격의 이물질이라도 온도에 따라 점도가 달라지므로 이에 선정에 각별한 유의해야 한다

• 흡입측 배관

흡입측 배관시 Air흡입이 되지 않도록 완전하게 Sealing을 하여 주시고 Elbow, Valve, Cock 등의 사용은 가능한 줄이십시오. 또한 흡입측 관은 굵고 짧게 하고 흡입시의 유속은 1.5m/sec이하가 되도록 하십시오

• 흡입측 Filter

흡입측에는 반드시 100Mesh 이상의 Filter를 사용하고 흡입압력은 0~0.15kg/cm² 이하가 되도록 하며 여과면적을 Pump 토출량의 2배 이상으로 하여 주십시오.

• 토출측 배관

토출측 배관은 유속이 3m/sec 이하가 되도록 하며 배관경이 작아 유속이 빠르면 Pump에 필요 이상의 부하가 걸리고 유량이 감소하며 유온상승의 원인이 됩니다.

• Oil Tank

오일탱크의 용량은 펌프의 분당 토출량의 3배 이상으로 하고 반드시 유면계를 부착하십시오.

Tank용량이 너무 적으면 유온이 상승하고 열화가 빠르며 흡입불량의 원인이 됩니다.

또한 흡입 Filter와 Drain Pipe와의 거리는 최대한 멀리 설치해 주시고 기포 및 이물질 혼입을 방지하기 위하여 Tank내에 2개 이상의 격판을 설치하여 주십시오.

• 유속 계산

· 흡입속도 1.5m/sec이하 · 토출속도 3m/sec이하

$$V = 4Q / \pi d^2$$

V : 유속(m/sec)

Q : 유량 (m³/sec)

d : 관의 내경(m)

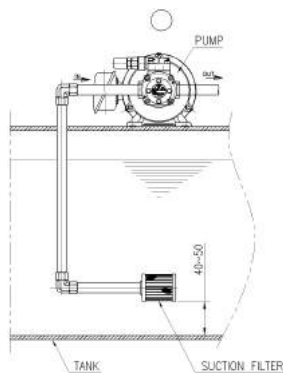

■ Check point of usage

• Pump location

The pump should be installed at good air flowing, low temperature and the least moist.and located higher than the using tank.

• Discharge volume, viscosity rotation frequency.

The discharge volume follows rotation frequency. standard frequency;1000-1800rpm. The proper viscosity is 20-1000cSt(40°C).

Be careful to select oil grade because the viscosity can be changed by temperature, even the same oil grade.

• Inlet pipe

The inlet pipe should be completely sealed not to contain the air when installing. Avoid to use the elbow, valve and cock as possible. The inlet pipe should be used larger and shorter pipe flowing the fluid speed under 1.5m/sec when sucking.

• Inlet filter

The filter should be fitted over 100mesh and sucking pressure below 0-0.15 kg/cm² The filtering area becomes over two times than the pump discharge volume.

• Outlet pipe

The flowing speed of outlet pipe should be below 3m/sec. If the pipe diameter is small and flowing speed is fast, the pump have overload and not only decreases volume but also causes higher oil temperature.

• Oil tank

The oil tank capacity must install over 3 times about minute's discharge volume, and attach level switch.

If the tank size is too small, it causes high oil temperature and faulty suction.

The distance of suction filter and drain pipe should be far as possible, and fit over 2 units of filtering plate to protect chips in the tank.

• Measure of flowing speed

· suction speed; below 1.5m/sec. · discharging speed; below 3m/sec.

$$V = 4Q / \pi d^2$$

V : flowing speed(m/sec)

Q : Discharge volume(m³/sec)

d : Inner diameter of pipe(m)

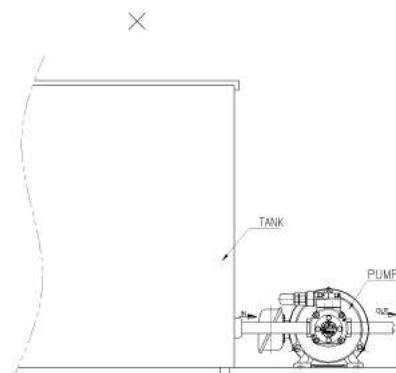

Motor 선정 시 주의사항

- 펌프의 토출량이 많아지거나 압력이 높아질수록 Motor의 소비동력은 증가합니다.
- 같은 종류의 오일 온도도 낮아지면 점도가 높아져 Motor의 소비동력은 증가합니다.(25°~40° 기준)

• 소요전력의 계산

Pump의 소요전력은 Pump의 축동력 외에도 오일의 점도와 온도에 의해 변화되므로 계절적 영향도 고려소요 동력을 산출할 때는 최악의 경우를 기준으로 하여 계산하십시오.

• 소요동력 계산식(축동력)

$$Lm(KW) = (P \cdot Q) / (612 \cdot \eta)$$

$$Lm(HP) = (P \cdot Q) / (450 \cdot \eta)$$

P : 토출압력(kg/cm²)

Q : 토출량(l/min)

η : 계수(펌프최대효율)

Discharge Pressure 토출압력 (kg/cm ²)	Efficiency 효율(η)	Discharge Pressure 토출압력 (kg/cm ²)	Efficiency 효율(η)
0~3	0.2~0.25	8~10	0.35~0.45
3~5	0.25~0.3	10~20	0.45~0.55
5~8	0.3~0.35	20~	0.55~0.65

운전 시 유의사항

- Pump 가동시에는 필히 회전방향을 확인할 것. 만약 역방향으로 장시간 회전하게 되면 Oil-seal이 파손되어 펌프를 사용할 수 없게 된다. 펌프에 표시되어있는 회전방향 표시 스티커 또는 양각표시를 참고할 것.
- 운전하기 전에 토출측에 약간의 오일을 주입하여 유막이 형성되도록 한 후 작동 시킬 것. 운반중 또는 장기간 작동시키지 않고 방치하여 펌프 내에 이이 건조된 상태에서 운전을 하게 되면 흡입불량과 소음발생하고 펌프가 파손될 위험이 있다.
- 이이 흡입되지 않는 상태에서 공회전을 하게 되면 축봉장치(Oil-seal)가 파손 될 수 있다
- 펌프에서 진동이나 이상음이 발생하면 즉시 운전을 정지하고 다음 점검 사항을 실시하여 문제점을 조차한 후 운전을 해야 한다.
 - 운반 중 파손, 조임 상태의 헐거움 등
 - Tank 유면의 적정성
 - 흡입배관 Sealing 상태
 - 사용유체의 점도
- 무리하게 높은 압력을 설정하게 되면 Motor의 과부하와 진동, 소음이 발생하게 되므로 적정한 압력설정을 해야 한다.

Check point of motor selection

- The motor power increases when the discharge volume becomes larger and the pressure increases higher.
- The motor power increases as the viscosity increases when the temperature becomes lower in the same oil grade.

• Calculation of electric power

The demanding electric power of pump depends on its working power itself as well as the oil viscosity and temperature by season.

When you measure the demanding electric power, it should be measured assuming the worst conditions.

• Demanding power measurement.

$$Lm(KW) = (P \cdot Q) / (612 \cdot \eta)$$

$$Lm(HP) = (P \cdot Q) / (450 \cdot \eta)$$

P : discharge pressure(kg/cm²)

Q : discharge volume(l/min)

η : factor(max. efficiency of pump)

Operating Check point

- Check the rotating direction. If the pump is operated with wrong direction for long time, the oil seal is easily broken. Refer the direction sticker or mark on the pump.
- Operate the pump after filling sufficient oil at outlet hole. If not, it makes noise or bad suction or broken to pump when the pump inside dries after long idling.
- The idle operation without filling oil causes the oil seal broken.
- When the vibration and strange noise occurs in the pump, stop immediately the operation of pump and check the below check point.
 - Pump broken or loosen of bolt when delivering.
 - Proper filling of oil in tank.
 - Sealing condition of inlet pipe.
 - Viscosity of using oil.
- Avoid the high pressure on pump.
The standard pressure should be set up, if not, it causes overload ,vibration and noise of pump.

T-ROTOR pumps

Technical data

Example System Assemble (시스템 구성의 예)

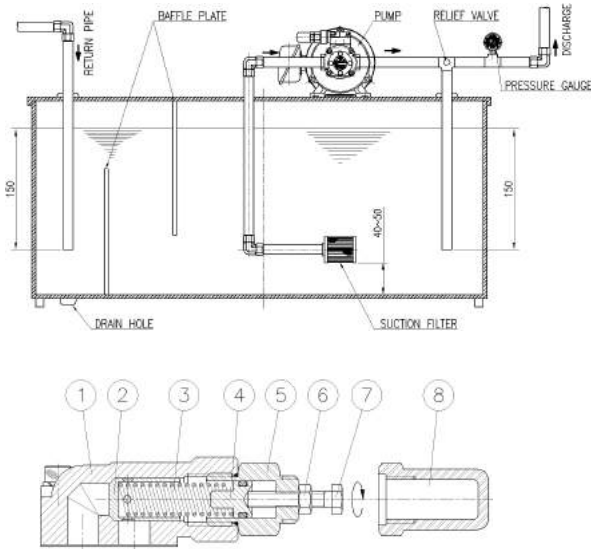

- ① Relief valve ② Piston ③ Spring ④ Spring seat
 ⑤ Plug bolt ⑥ Lock nut ⑦ Adjust bolt ⑧ Cap nut

Relief valve 조절방법

Control of relief valve

- 1) Increasing; the pressure increases when you open the cap nut in relief valve and turn the adjusting bolt to right direction.
 - Relief valve의 ⑧Cap nut를 열고 ⑦육각 Adjust bolt를 우측으로 돌리면 압력 증가
- 2) Decreasing ; The pressure decreases when the adjusting bolt turns to left direction.
 - ⑦육각 Adjust bolt를 좌측으로 돌리면 압력 감소
- 3) The lock nut fixing and then cap nut closing after adjusting pressure.
 - 압력조절이 끝나면 ⑥Lock nut를 조이고 ⑧Cap nut를 닫는다.

Analysis drawing 분해도 (ATP-HAVB)

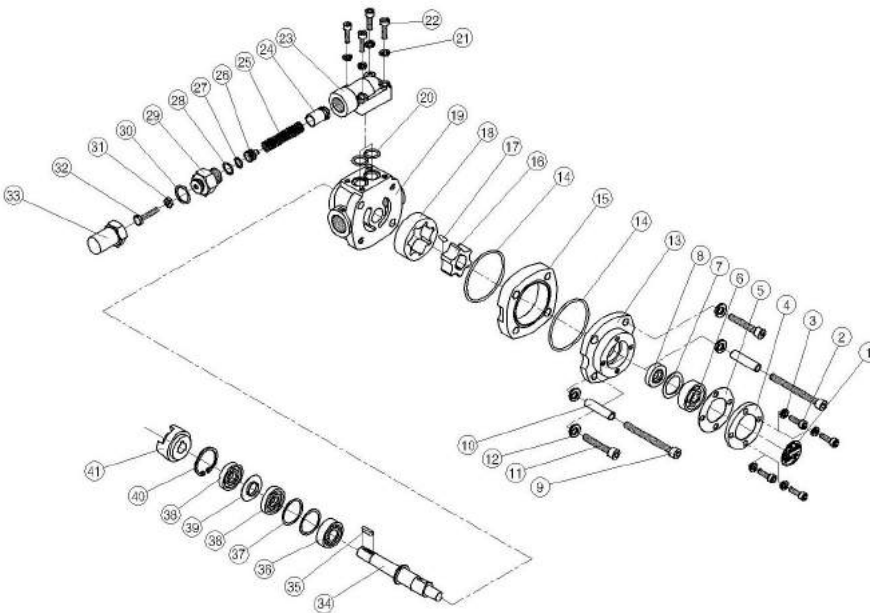

Part List

No.	PART NAME	No.	PART NAME
1	Name plate	22	Wrench Bolt
2	Wrench Bolt	23	Relief V/V Body
3	Spring washer	24	Piston
4	Bearing cover	25	Spring
5	Packing	26	Spring Seat
6	Ball bearing	27	O-ring
7	Spacer Collar	28	O-ring
8	Oil Seal	29	Plug Bolt
9	Wrench Bolt	30	Packing
10	Sus Pipe	31	Lock Nut
11	Wrench Bolt	32	Adjust Bolt
12	Spring Washer	33	Cap Nut
13	Pump Cover	34	Shaft
14	O-ring	35	Key
15	Pump Body	36	Ball Bearing
16	Inner Rotor	37	Spacer Collar
17	Round Key	38	Oil seal
18	Outer Rotor	39	Back up ring
19	Port Housing	40	Snap Ring
20	O-ring	41	Pump Coupling
21	Spring Washer		

Change of viscosity by temperature 온도에 따른 동점도 (cSt) 변화

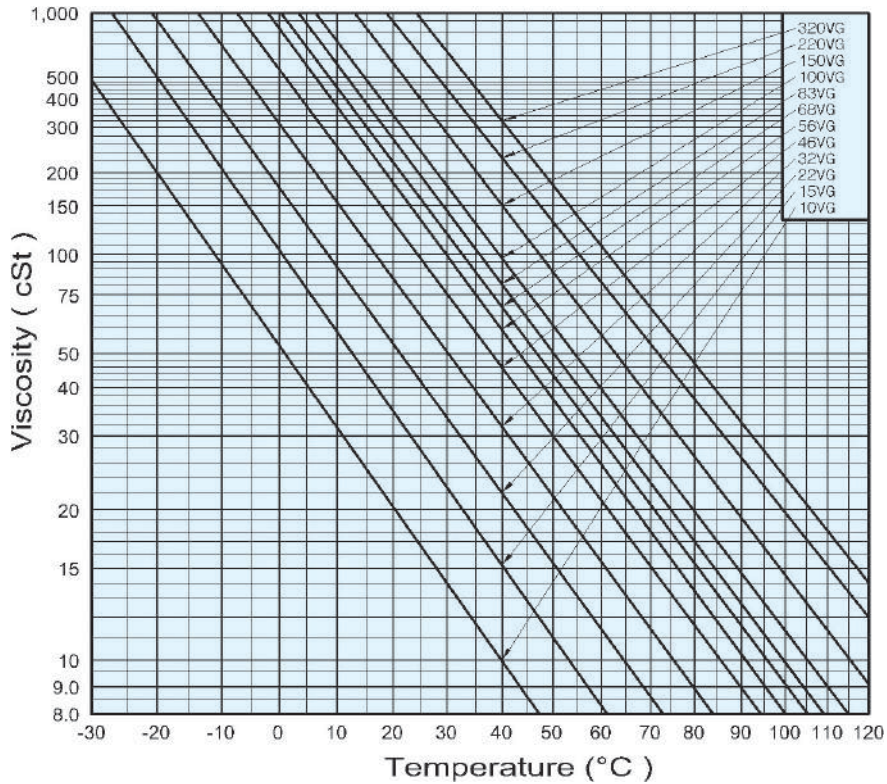

Temperature (°C)	VG2	VG3	VG5	VG7	VG10	VG15	VG22	VG32	VG46	VG68	VG100	VG150	VG220	VG320	VG460
-20	-	-	-	-	-	-	-	1170	3600	8000	-	-	-	-	-
-10	-	-	-	-	-	-	-	440	1270	2500	4500	-	-	-	-
0 (1°C)	4 (1°C)	10 (1°C)	17 (1°C)	32 (1°C)	52 (1°C)	109 (1°C)	169 (1°C)	240	520	950	1600	3570	5329	8990	15350
10	4	7	12	20	32	62	93	135	261	433	772	1237	1996	3211	5200
20	3	5	9	14	20	36	53	76	134	212	356	553	861	1328	2050
30	3	4	6	9	14	23	33	46	76	115	184	277	417	620	920
40	2	3	5	7	10	15	22	32	46	68	100	150	220	320	460
50	2	3	4	5	7	11	15	21	30	43	63	91	129	180	250
60	2	2	3	4	6	8	11	15	21	29	41	57	80	108	146
70	1	2	2	3	4	6	8	11	15	20	28	39	52	70	92
80	1	2	2	3	4	5	7	9	11	15	20	27	36	47	60
90	1	1	2	2	3	4	5	7	9	11	15	20	26	33	42
100	1	1	2	2	2.6	3.4	4.3	5.3	6.7	8.5	11.1	14.5	18.7	24	30.2
110	-	-	1	2	2	3	4	5	6	7	9	12	15	18	23
120	-	-	-	1	2	2	3	4	5	6	7	9	12	14	17

As the above data are for user's reference, the figures can be different by oil producers.
본 자료는 사용자의 이해를 돕기 위한 참고자료이며 각 OI 제조사에 따라 특성이 다를 수 있다.

T-ROTOR pumps

AR1-F Series

AR1 - 3F

Pump division
펌프구분



- AR1-F형의 펌프는 회전방향의 정 역에 관계없이 흡입, 토출되는 방향은 항상 일정하게 이루어지는 가역식 펌프이다.
- The AR1-F type delivers constantly the oil suction and discharge to one direction whether the pump rotating direction is right or left.
- 주 용도는 공작기계, 산업기계, 기타 범용기계의 윤활공급용으로 적합하다.
- This type is mainly applied machine tools, industrial machine for transferring the oil.

Type	1회전당 cm ³ /rev	Discharge volume 토출유량 ℓ / min		Per- missive Pressure 허용압력 MPa	Per- missive Rotation 허용 회전수 rpm	Net weight 중량 kg
		1000rpm	1800rpm			
AR1-2F	2.0	2.0	3.6	0.5	500-2000	1.2
AR1-3F	2.5	2.5	4.5	0.5	500-2000	1.3

External dimensions 외형도

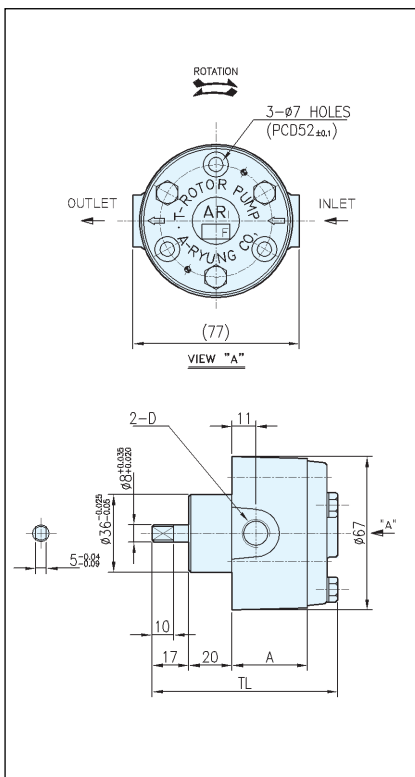

Type	A	TL	D (Port dia)	
			INLET	OUTLET
AR1-2F	32	83	PT 1/4"	PT 1/4"
AR1-3F	35	86		

● Applications 적용

Type of fluid 사용유체 : Oils
Viscosity 점도 (40°C 기준) : 20 ~ 1000 cSt
Temperature 사용온도 : 80°C

● Material 재질

Pump body : Cast iron
Pump cover : Cast iron
Shaft : Steel
Rotor : Powder steel
Oil-seal : NBR (∅8×∅18×7)

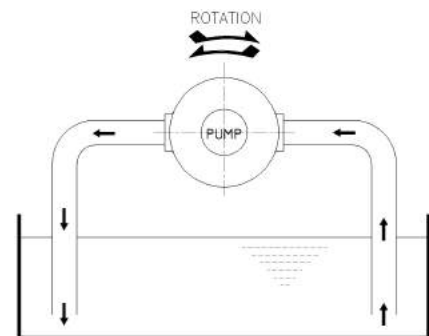

Suction and discharge by rotation direction
회전방향에 의한 흡·토출구

AR2-FC Series

AR2 - 4FC

Pump division
펌프구분



- AR2-FC형의 펌프는 회전방향의 정·역에 관계 없이 흡입, 토출되는 방향은 항상 일정하게 이루어지는 가역식 펌프이다.
- 주 용도는 감속기, 냉동기, 콤푸레셔, 철도차량, 선박 엔진, 공작기계 등의 윤활공급용으로 적합하다.
- The AR2-FC type delivers constantly the oil suction and discharge to one direction whether the pump rotating direction is right or left.
- This type is mainly applied reducer, cooler, compressor, rail, ship engine, machine tools for transferring the oil.

Type	회전당 cm ³ /rev	Discharge volume 유량 Q/min		Per- missive Pressure 허용압력 MPa	Per- missive Rotation 허용회전수 rpm	Net weight 중량 kg
		1000rpm	1800rpm			
AR2-4FC	4	4	7.2	0.5	500-2000	3.9
AR2-8FC	8	8	14.4	0.5	500-2000	4.3
AR2-12FC	12	12	21.6	0.5	500-2000	4.7

External dimensions 외형도

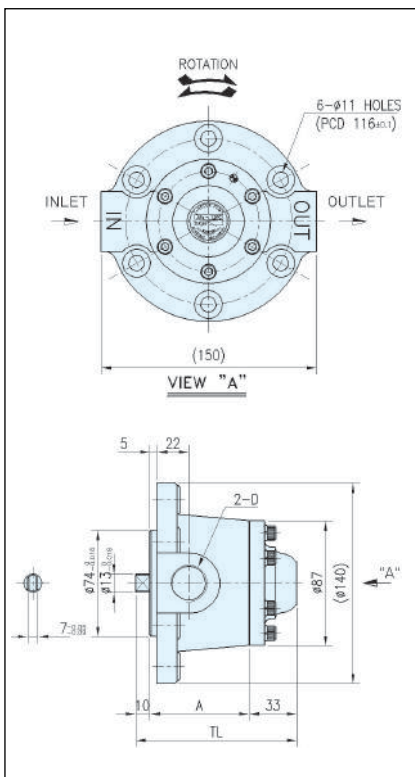

Type	A	TL	D (Port dia)	
			Inlet	Outlet
AR2-4FC	49	92	PT 1/2"	PT 3/8"
AR2-8FC	59	102	PT 3/4"	PT 1/2"
AR2-12FC	69	112	PT 3/4"	PT 3/4"

●Applications 적용

Type of fluid 사용유체 : Oils
Viscosity 점도 (40°C 기준)
: 20 ~ 1000 cSt
Temperature 사용온도 : 80°C

●Material 재질

Pump body : Cast iron
Pump cover : Cast iron
Shaf : Steel
Rotor : Powder steel
Oil-seal : NBR (Ø13×Ø30×8t)

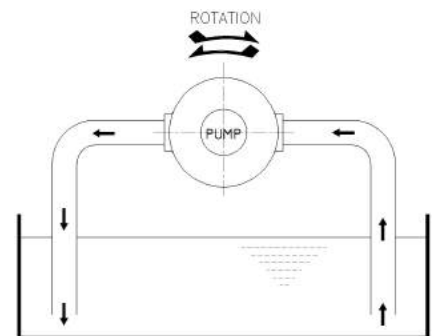

Suction and discharge by rotation direction
회전방향에 의한 흡, 토출구

T-ROTOR pumps

ATP-S Series



ATP - 11 S VB

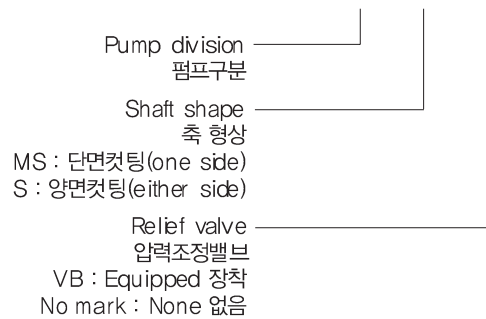

External dimensions 외형도

ATP-S(MS)

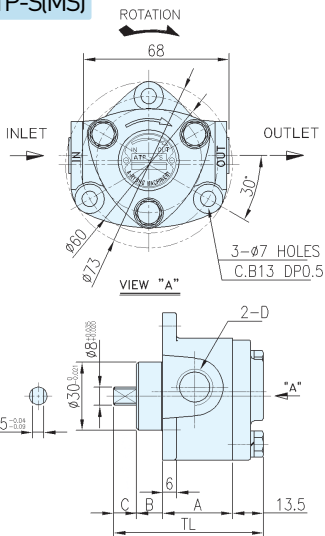

ATP-SVB(MSVB)

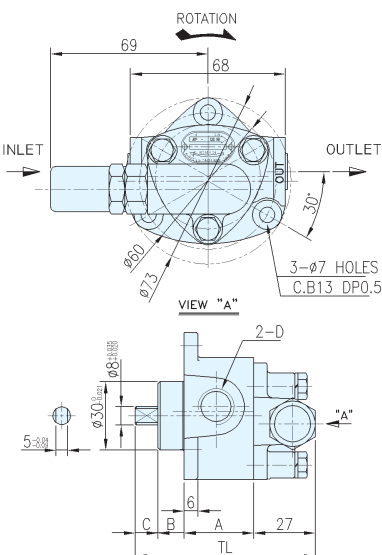

- ATP-S 형은 소형 기어 펌프로서 각종의 공작기계 산업용 기계 농업용 기계 등의 윤활 공급용으로 주로 사용된다.
- 이 펌프는 지정된 한쪽 방향으로만 일정하게 회전하며, 기계의 동력이나 또는 모터와 조합되어 운전이 가능하다. 자체 Relief가 내장되어 압력조절이 용이하다. (선택)

- ATP-S series is compact gear pump. It is widely used for supply of lubrication oil for various working tools, industrial machine and farming implements, etc.
- It should be rotated only in the constant direction. According to the driving system, it is possible to drive by power of machine and by motor. (Relief valve option)

Type	1회전당 cm ³ /rev	Discharge volume 토출유량 ℓ /min		Per- missive Pressure 허용압력 MPa	Per- missive Rotation 허용회전수 rpm	Net weight 중량 kg
		1500rpm	1800rpm			
ATP-11S(MS)	1.6	2.4	2.9	0.5	300-2000	0.3
ATP-12S(MS)	2.5	3.7	4.5	0.5	300-2000	0.3
ATP-13S(MS)	4.5	6.7	8.1	0.5	300-2000	0.8
ATP-11SVB(MSVB)	1.6	2.4	2.9	0.5	300-2000	0.5
ATP-12SVB(MSVB)	2.5	3.7	4.5	0.5	300-2000	0.6
ATP-13SVB(MSVB)	4.5	6.7	8.1	0.5	300-2000	1.0

Type	A	B	C	TL	D (Port dia)	
					Inlet	Outlet
ATP-11S(MS)	25.5	11.5	10	61	PT 1/8"	PT 1/8"
ATP-12S(MS)	30.5	11.5	10	66	PT 1/4"	PT 1/4"
ATP-13S(MS)	45	5	14.5	78.5	PT 3/8"	PT 3/8"
ATP-11SVB(MSVB)	25.5	11.5	10	74	PT 1/8"	PT 1/8"
ATP-12SVB(MSVB)	30.5	11.5	10	79	PT 1/4"	PT 1/4"
ATP-13SVB(MSVB)	45	5	14.5	91.5	PT 3/8"	PT 3/8"

• Applications 적용

- Type of fluid 사용유체 : Oils
- Viscosity 점도 (40°C 기준) : 20 ~ 1000 cSt
- Temperature 사용온도 : 80°C

• Material 재질

- Pump body : Cast iron
- Pump cover : Cast iron
- Shaf : Steel
- Rotor : Powder steel
- Oil-seal : NBR
Ø8×Ø22×7

ATP-HA Series



ATP - HA



ATP - HAVB



ATP - HAB



ATP - HABVB

ATP - 204 HA VB 1.5

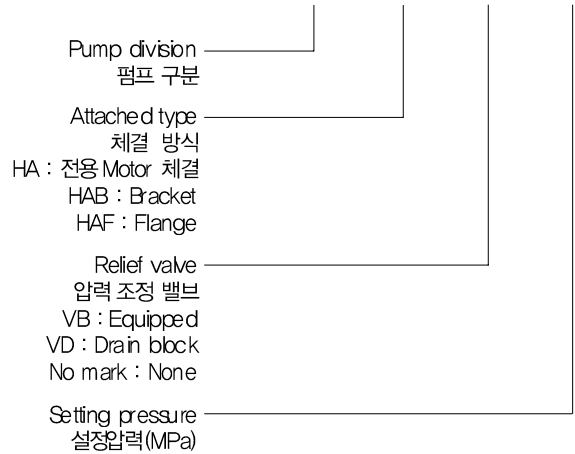

- ATP-HA 형 펌프는 축봉장치용 Oil-seal을 이중으로 적용하여 내구성이 우수하다.
- 열매체용으로 사용할 시는 불소재질의 Oil-seal을 적용하여 180°C이하의 고온에서도 사용이 가능하다.(선택사양)
- 압력조절이 가능한 Relief valve가 부착되어 있어 Motor 및 Pump의 부하를 줄여 안전하게 사용할 수가 있다.(선택사양)
- 오일 및 연료이송, 공작기계 및 각종 산업기계의 윤활급유, 유압장치 등에 적합하다.
- ATP-HA pump is applied double oil seal and have excellent endurance.
- For using in high temperature. This type can be endure high temperature (below 180°C) applying the oil seal used the FKM Material. (Option)
- This pump has a relief valve to control the pressure so that can avoid the load in motor and pump operation.(Option)
- This pump is used transferring of oil and fuel, lubrication of machine and tools, hydraulic applications.

Type	회전량 cm ³ /rev	Discharge volume 토출 유량 ℓ/min		Max' Pressure 최대압력 MPa	Per- missive Rotation 허용회전수 rpm	Net weight 중량 kg	
		1500rpm	1800rpm			HA HAF	HAVB HAVD
ATP-204HA	4.2	6.3	7.5	3.0	300-2500	3.2	3.6
ATP-206HA	6.0	9.0	10.8	3.0	300-2500	3.2	3.6
ATP-208HA	8.4	12.6	15.1	3.0	300-2500	3.3	3.7
ATP-210HA	10.2	15.3	18.3	3.0	300-2500	3.4	3.8
ATP-212HA	12.0	18.0	21.6	3.0	300-2000	3.6	4.0
ATP-216HA	16.2	24.3	29.1	3.0	300-1800	3.8	4.2
ATP-220HA	19.8	29.7	35.6	3.0	300-1800	4.1	4.5

Relief valve

Division 구분	Domain 압력범위 MPa
1S	0 - 0.4
2S	0.4 - 0.8
3S	0.6 - 1.5
4S	1.2 - 3.0

T-ROTOR pumps

External dimensions 외형도

ATP - HA

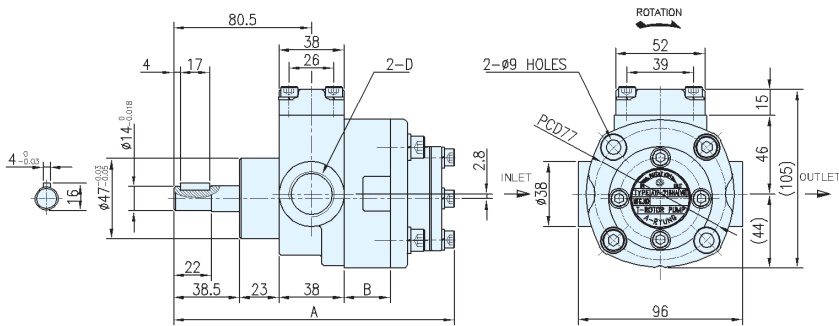

ATP - HAF

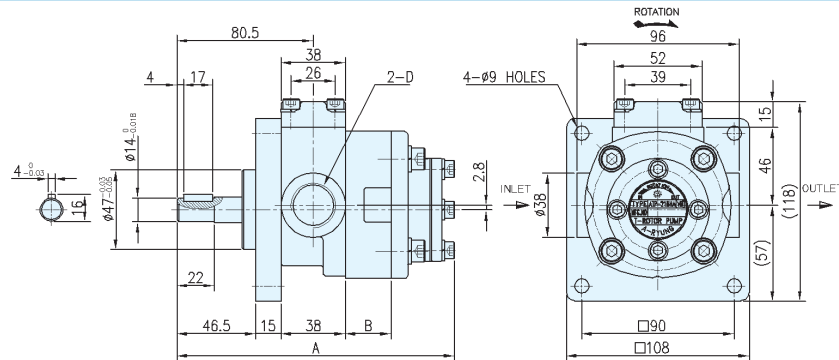

ATP - HABVB

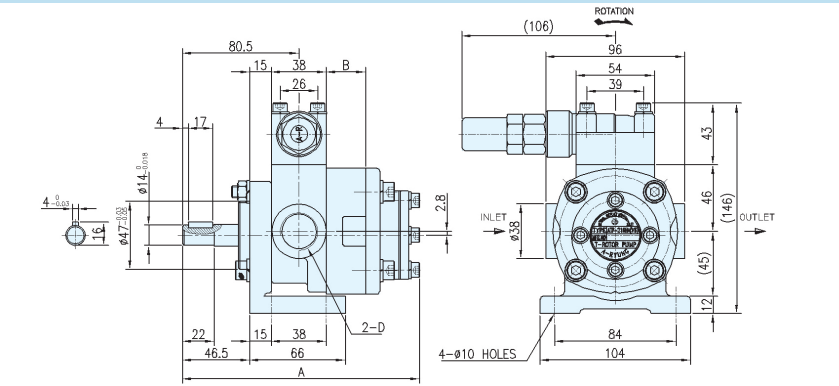

ATP - HABVD

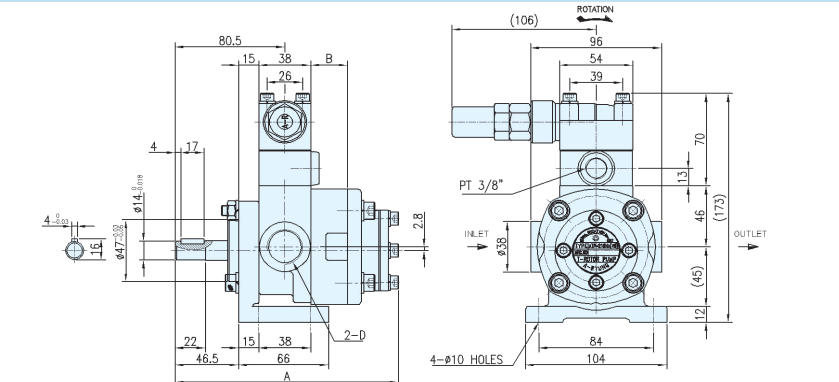

Type	A	B	D (Port dia)	
			Inlet	Outlet
ATP-204 HA HAB HAF HAVB HAVD	145	7		
ATP-206 HA HAB HAF HAVB HAVD	148	10	PT 1/2"	PT 1/2"
ATP-208 HA HAB HAF HAVB HAVD	152	14		
ATP-210 HA HAB HAF HAVB HAVD	155	17		
ATP-212 HA HAB HAF HAVB HAVD	158	20	PT 3/4"	PT 3/4"
ATP-216 HA HAB HAF HAVB HAVD	165	27		
ATP-220 HA HAB HAF HAVB HAVD	172	33		

● Applications 적용

Type of fluid 사용유체 : Oils
 Viscosity 점도 (40°C기준) : 20 ~ 1000 cSt
 Temperature 사용온도 : NBR 80°C
 FKM 180°C

● Material 재질

Pump body : Cast iron
 Port housing : Cast iron
 Pump cover : Cast iron
 Bearing : #6202zz, #6301zz
 Shaft : Steel
 Rotor : Powder steel
 Oil-seal : NBR, FKM(Option)
 Ø15×Ø35×7t
 Ø17×Ø30×8t
 Relief valve : Cast iron etc.

Characteristic curves 성능 곡선

ATP - 204HA(VB/VD)

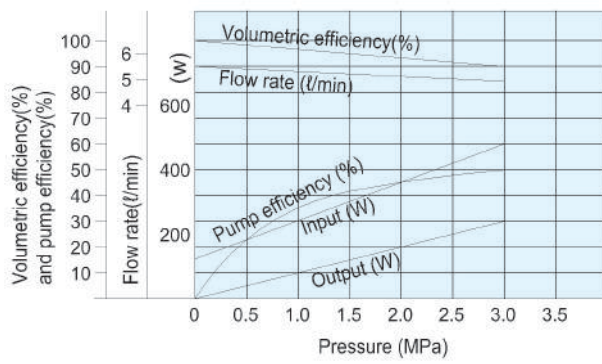

ATP - 206HA(VB/VD)

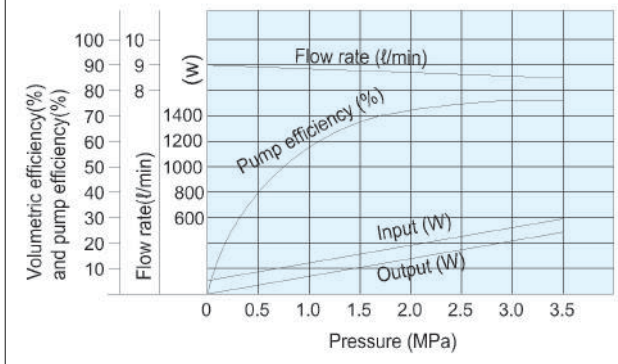

ATP - 208HA(VB/VD)

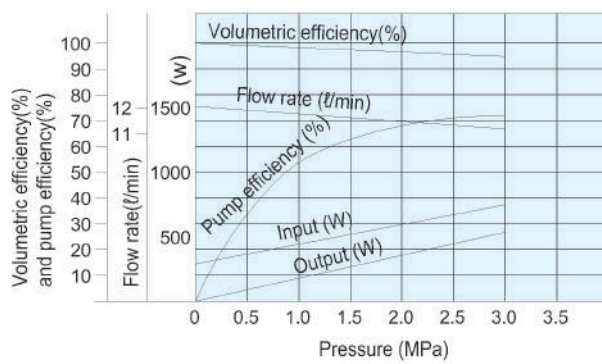

ATP - 210HA(VB/VD)

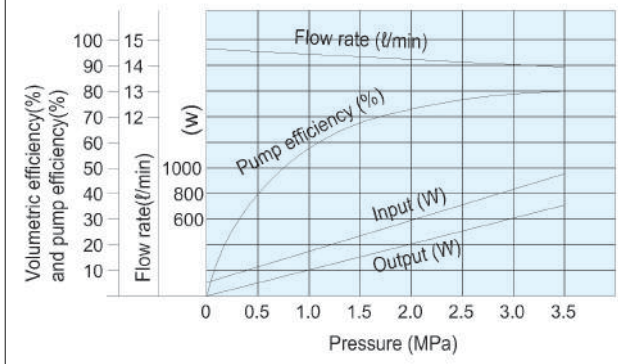

ATP - 212HA(VB/VD)

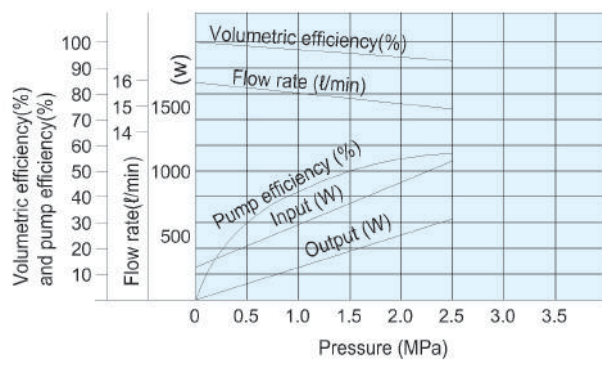

ATP - 216HA(VB/VD)

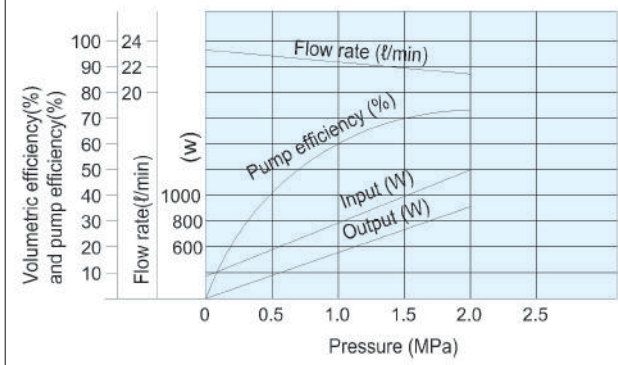

ATP - 220HA(VB/VD)

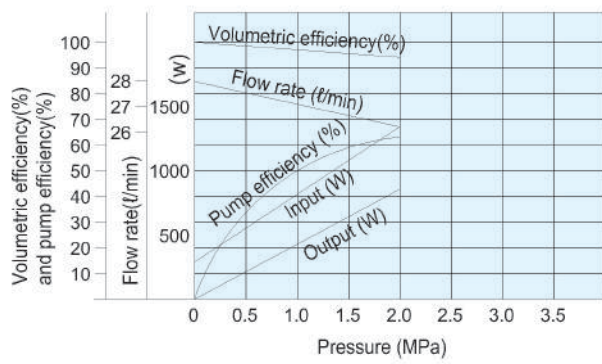

- Oil used 사용유체 : #46 turbine oil
- Oil temperature 유온 : 40°C
- Speed 회전수 : 1500rpm

T-ROTOR pumps

ATP -H/HF Series



ATP - 320 H VB 1.0

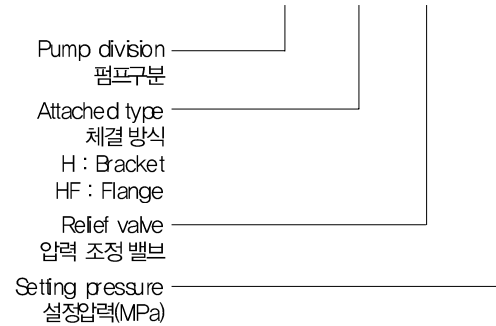

- ATP-320HVB형 펌프는 내열용 OI-seal을 적용하여 내구성이 우수하며 열매체용으로 사용할 때는 180°C이하의 고온에서도 사용이 가능하다.
- 압력조절이 가능한 Relief valve가 부착되어 있어 Motor 및 Pump의 부하를 줄여 안전하게 사용할 수가 있다.
- 공작기계 및 각종 산업기계의 오일 및 연료이송, 윤활급유, 유압장치 등에 적합하다.
- ATP-320HVB pump is applied the oil seal enduring high temperature and have excellent endurance. This type can be endure high temperature. (below 180°C)
- This pump has a Relief valve to control the pressure so that can avoid the load in motor and pump operation.
- This type is used transferring of oil and fuel, lubrication of machine and tools, hydraulic applications.

Type	1회전당 cm ³ /rev	Discharge volume 토출 유량 Q / min		Maximum Pressure 최대압력 MPa	Per- missive Rotation 허용 회전수 rpm	Net weight 중량 kg
		1500rpm	1800rpm			
ATP-320HVB 320HFVB	26.0	39.0	46.8	3.0	1800	16.4
ATP-340HVB 340HFVB	52.0	78.0	93.6	3.0	1500	17.0

Relief valve

Division 구분	Domain 압력범위 MPa
1S	0 - 0.4
2S	0.4 - 0.8
3S	0.6 - 1.5
4S	1.2 - 3.0

External dimensions 외형도

ATP - 320/340HVB

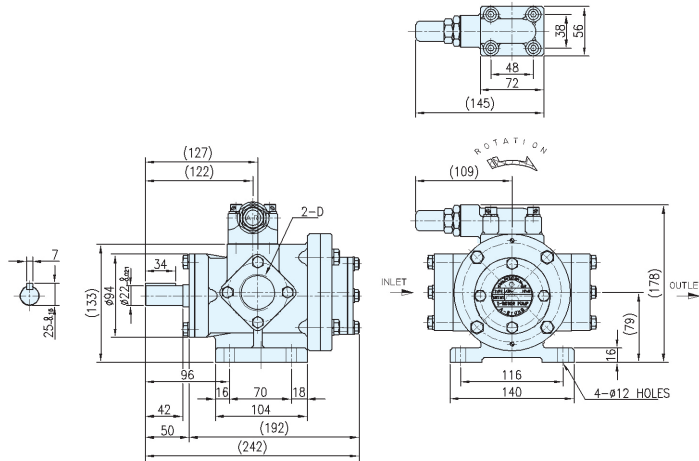

Type		D (Port dia)	
		Inlet PT	Outlet PT
ATP-320	HVB HFVB	1"	1"
ATP-340	HVB HFVB	1 1/4"	1"

●Applications 적용

Type of fluid 사용유체 : Oils
 Viscosity 점도 (40°C기준) : 20 ~ 1000 cSt
 Temperature 사용온도 : FKM 180°C

●Material 재질

Pump body : Cast iron
 Port housing : Cast iron
 Pump cover : Cast iron
 Bearing : #6305zz, #63/22zz
 Shaft : Steel
 Rotor : Powder steel
 Oil-seal : FKM
 Relief valve : Cast iron etc.

ATP - 320/340HFVB

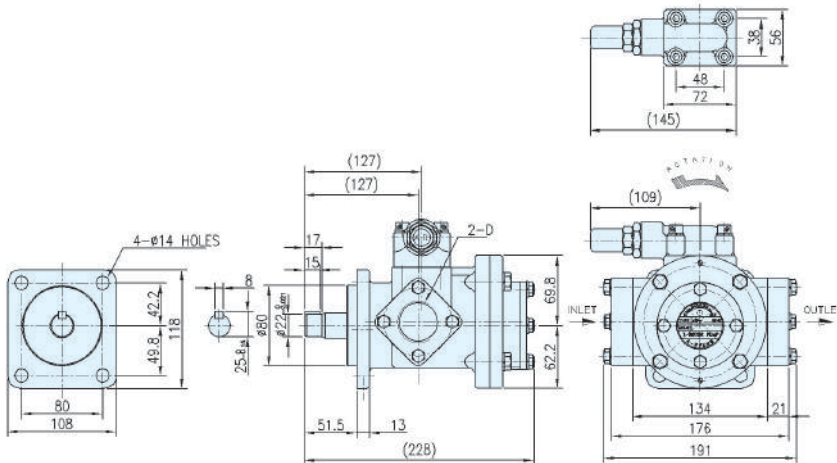

Characteristic curves 성능 곡선

ATP - 320HVB/HFVB

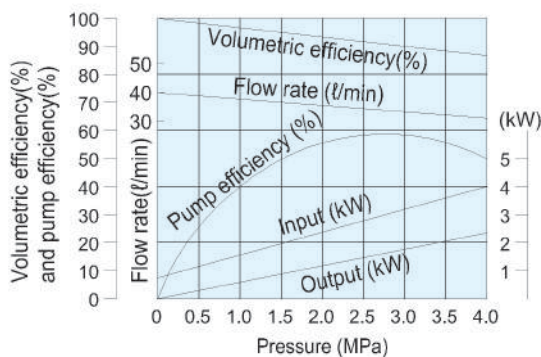

ATP - 340HVB/HFVB

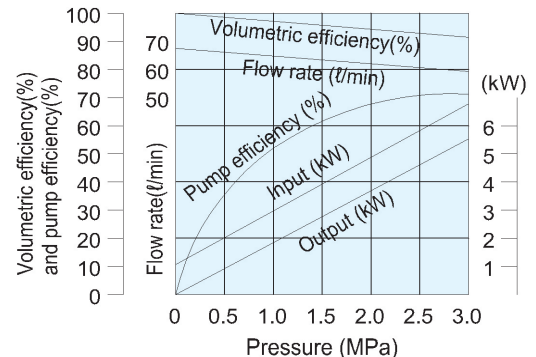

- Oil used 사용유체 : #46 turbine oil
- Oil temperature 유온 : 40°C
- Speed 회전수 : 1500rpm

T-ROTOR pumps

ATP - 4** HVB Series



ATP - 420H VB 0.3

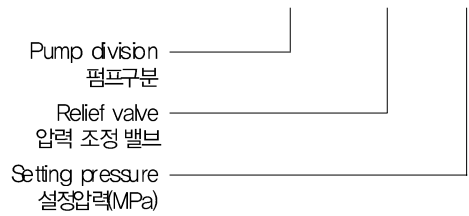

External dimensions 외형도

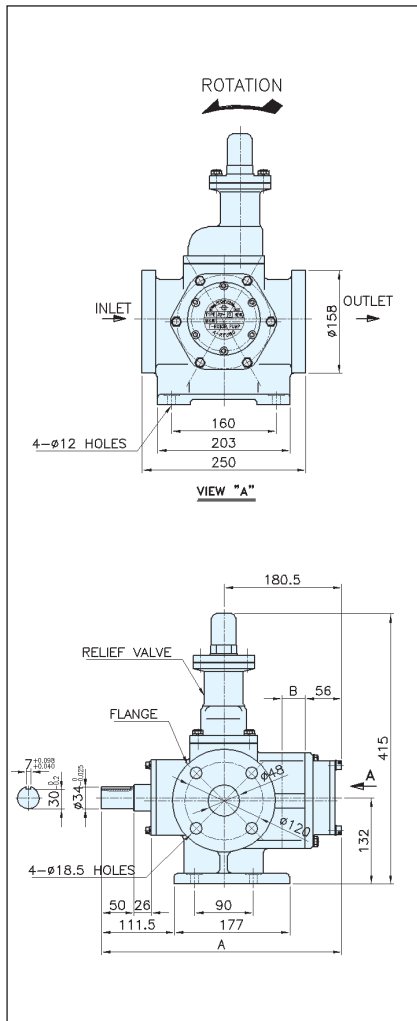

- 대유량 펌프로서 선박, 산업기계 등의 각종 오일, 버커 C 연료 및 윤활성이 있는 액체이송용으로 적합하다.
- 압력조절이 가능한 Relief valve가 부착되어 있어 Motor 및 Pump의 부하를 줄여 안전하게 사용할 수가 있다.

- This type is large discharge volume pump, and used ship industry, machine tools, general oil, bucket C oil transferring of fluid.
- This pump has a relief valve to control the pump pressure so that can avoid the load in motor and pump operation.

Type	회전당 cm ³ /rev	Discharge volume 토출 유량 Q /min			Per- missive Pressure 허용 압력 MPa	Per- missive Rotation 허용 회전수 rpm	Net weight 중량 kg
		1000rpm	1200rpm	1800rpm			
ATP-420HVB	90	90	108	162	0.5	1800	44.0
ATP-440HVB	180	180	216	-	0.3	1200	45.0

Note) "표"의 Data 작성은 유체 VG46을 기준으로 한 것이며 이보다 더 점도가 높은 유체를 사용할 시는 동력을 적절히 증가 시켜야 한다.

Note) Above data is for VG46 usage. The electric power has to be increased according to using for high liquid viscosity.

• Applications 적용

- Type of fluid 사용유체 : Oils
- Viscosity 점도 (40°C 기준) : 400cSt - 1800rpm, 500cSt - 1500rpm, 1000cSt - 1200rpm이하
- Temperature 사용온도 : 0°C ~ 180°C

• Material 재질

- Pump body : Cast iron
- Port housing : Cast iron
- Pump cover : Cast iron
- Bearing : #6208zz, 6207zz
- Shaft : Steel
- Rotor : Powder steel
- Oil-seal : FKM, Ø40×Ø62×11t
- O-Ring : NBR
- Relief valve : Cast iron etc.

ATP - 4** HVB Series

Example System Assembly 시스템 구성 예)

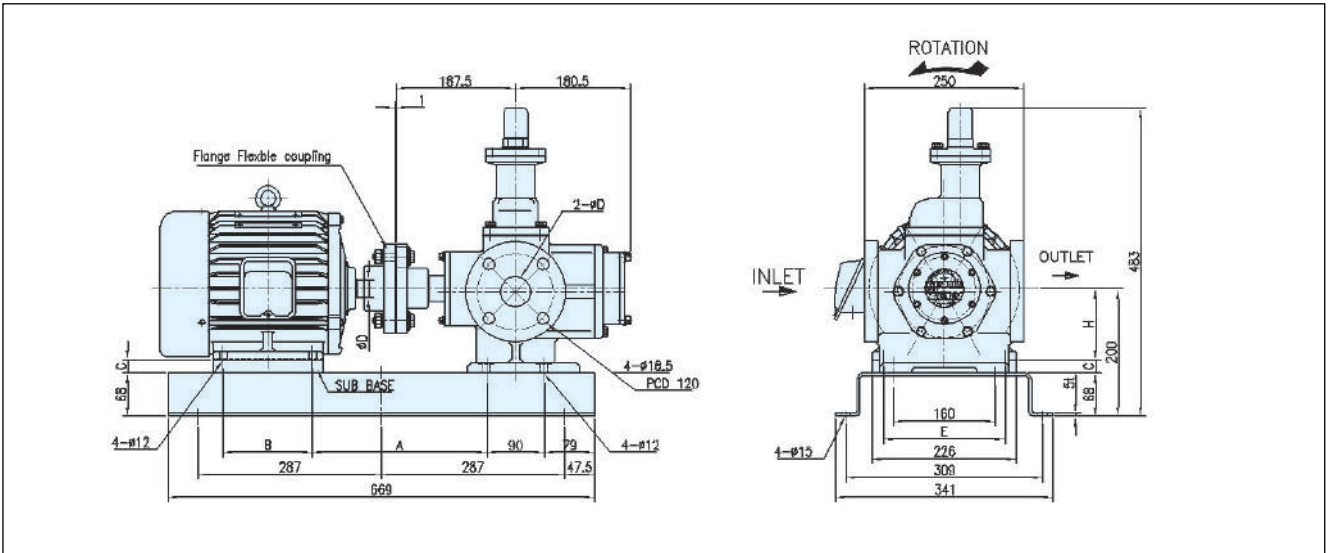

Type	A	B	C	ØD	E	H	D (Port dia) (KS10K-50A)	
							Inlet	Outlet
2.2kW(3Hp 6p)	273.5	140	20	28	190	112	2"(50A)	2"(50A)
3.7kW(5Hp 4p)	273.5	140	20	28	190	112		
3.7kW(5Hp 6p)	312.5	140	-	38	216	132		

Note) 적용 Motor의 치수는 국내에서 제조되는 표준 Motor를 기준으로 작성되었으나 제조사에 따라 규격이 상이할 수 있으므로 필히 확인 후 적용해야 한다.

Note) A-RYUNG generally uses Korean standard motor. Check the motor specification when you fit the motor because the motor is different every producer.

Assembly Base

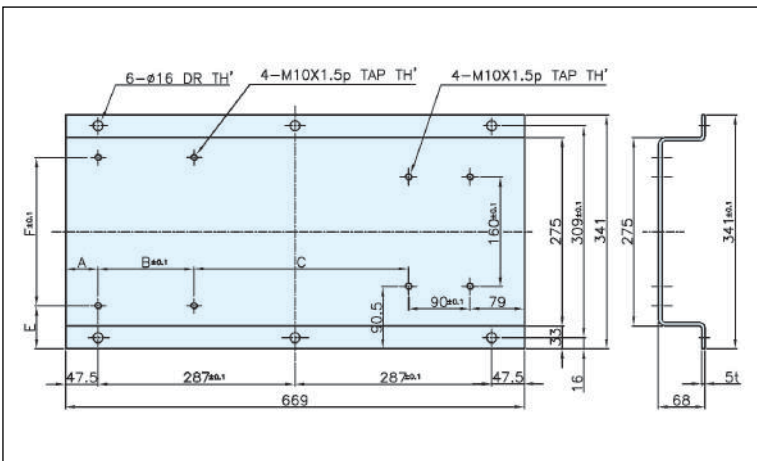

Type	A	B	C	E	F	G	Sub Base
2.2kW(3Hp 6p)	86.5	140	273.5	75.5	190	28	○
3.7kW(5Hp 4p)	86.5	140	273.5	75.5	190	28	○
3.7kW(5Hp 6p)	47.5	140	312.5	62.5	216	38	×

Sub Base

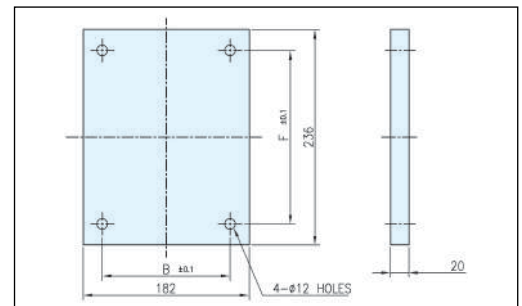

Flange Flexible Coupling (# 140)

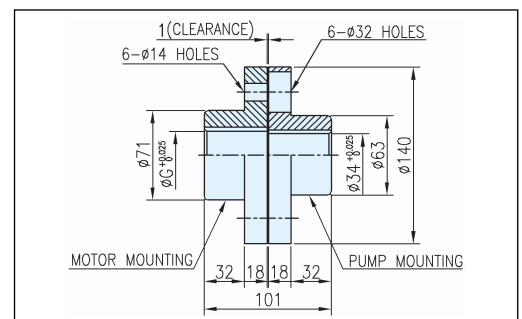

Motor T-ROTOR pumps

AMTP-MS, MT Series



AMTP - 200 - 12 MS F VB

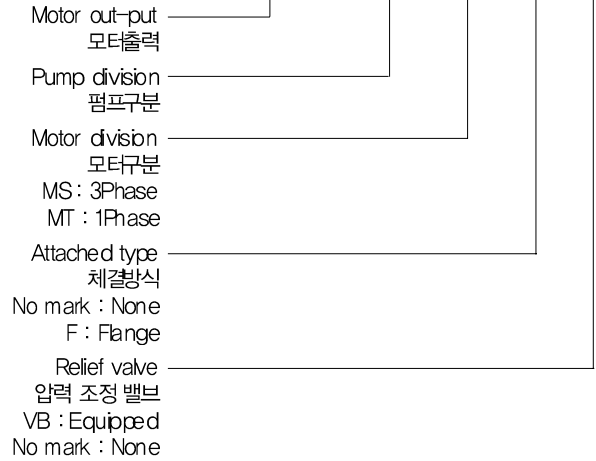

- AMTP-MS, MT형 펌프는 소형 T-ROTOR 펌프로서 Motor 와 Pump를 일체형으로 조합하여 Compact하게 설계되었으며, Motor와 Pump의 결합 및 분리가 간편하여 유지보수가 매우 용이하다.
- AMTP-MS& MT is a small T-ROTOR pump, and combined motor and pump. it is very compact and it is easy to assemble and dismantle between pump and motor.
- 압력조절이 가능한 Relief valve가 부착되어 있어 Motor 및 Pump의 부하를 줄여 안전하게 사용할 수가 있다. (선택사항)
- This pump has a relief valve to control the pump pressure so that can avoid the load in motor and pump operation.(Option)
- 공작기계 및 각종산업기계의 윤활유, 유체이송 등에 적합하다.
- This type is used lubrication in machine& tools and transferring of oil& fluid.

Type	50Hz 4p (1500rpm)			60Hz 4p (1800rpm)			Net weight 중량 kg
	Dis-charge Volume 유량 Q/min	Maximum pressure per Motor output 모터출력에 대한 최고압력 MPa		Dis-charge Volume 유량 Q/min	Maximum pressure per Motor output 모터출력에 대한 최고압력 MPa		
		100W	200W		100W	200W	
AMTP-11 ※※	2.4	0.5	-	2.9	0.5	-	7.2
AMTP-12 ※※	3.7	0.5	0.5	4.5	0.5	0.5	7.2
AMTP-13 ※※	6.7	-	0.5	8.1	-	0.5	7.7
AMTP-11 ※※VB	2.4	0.5	-	2.9	0.5	-	7.5
AMTP-12 ※※VB	3.7	0.5	0.5	4.5	0.5	0.5	7.5
AMTP-13 ※※VB	6.7	-	0.5	8.1	-	0.5	8.0

Type	Motor Output 출력 kW	Motor speed 회전수 rpm	Phase 상수 Ø	Poles 극수 P	Fre- quency 주파수 Hz	Rated voltage 전압 V	Current 전류 A
200W	0.2	1745	1	4	60	220	3.00
100W	0.1	1430	3	4	50	200	0.65
						380	0.38
						220	0.60
200W	0.2	1430	3	4	50	380	0.38
						440	0.30
						200	1.30
200W	0.2	1710	3	4	60	380	0.75
						440	0.55
						220	1.10

◆ Enclosure class 보호등급 : P44 ◆ Insulation class 절연계급 : E

External dimensions 외형도

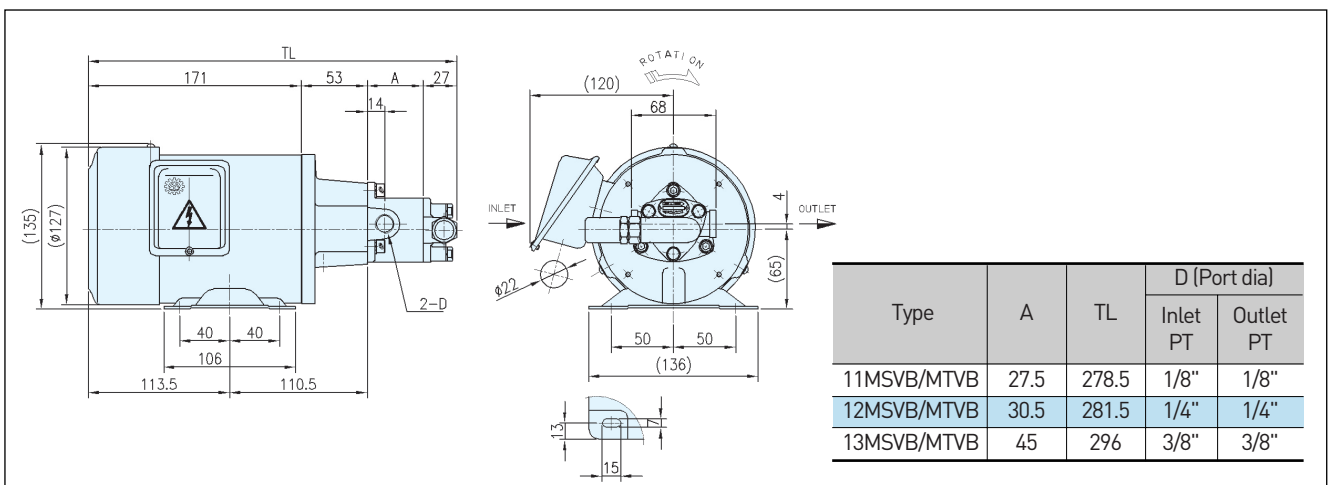
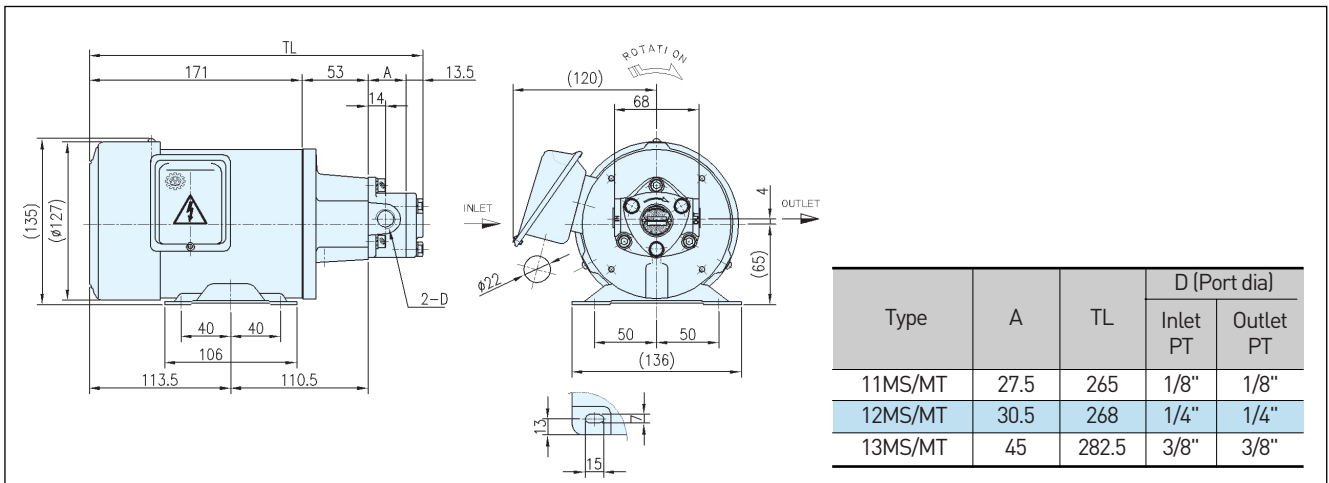
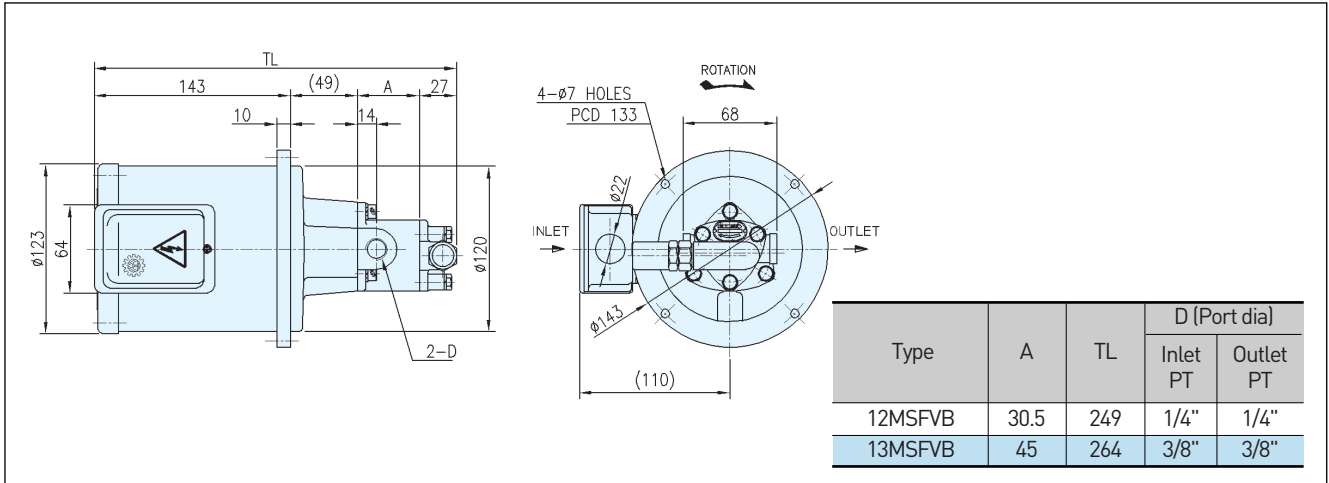

● Applications 적용

Type of fluid 사용유체 : Oils
 Viscosity 점도 (40°C기준) : 20 ~ 1000 cSt
 Temperature 사용온도 : NBR 80°C

● Material 재질

Motor frame : Steel Rotor : Powder steel
 Pump body : Cast iron Oil-seal : NBR FKM(Option)
 Pump cover : Cast iron ø8 × ø22 × 7t
 Shaft : Steel

Motor T-ROTOR pumps

AMTP-HA Series



AMTP - 750 - 204HA VB 1.5

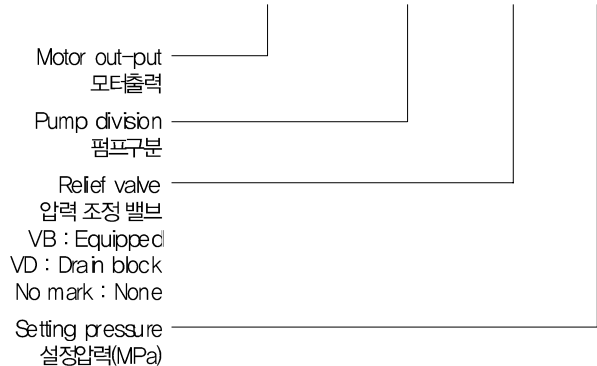

- AMTP-HA형 펌프는 Motor와 Pump를 조합하여 Compact하게 제작되어 설치위치의 제약을 적게 받으며 Motor와 Pump의 결합 및 분리가 간편하여 유지보수가 매우 용이하다.
- 축봉장치용 Oil-seal을 이중으로 적용하여 내구성이 우수하다.
- 열매체용으로 사용할 시는 불소재질의 Oil-seal을 적용하여 180°C이하의 고온에서도 사용이 가능하다.(선택사항)
- 압력조절이 가능한 Relief valve가 부착되어 있어 Motor 및 Pump의 부하를 줄여 안전하게 사용할 수가 있다.(선택사항)
- 공작기계 및 각종 산업기계의 오일 및 연료이송, 윤활급유, 유압장치 등에 적합하다.
- AMTP-HA type is combined motor with pump, so compact that it is easy to fit and to separate motor and pump part.
- The double oil seal improves endurance.
- For using in high temperature. This type can endure high temperature (below 180°C) applying the oil seal used the FKM material. (Option)
- This pump has a relief valve to control the pump pressure so that can avoid the load in motor and pump operation. (Option)
- This pump is used transferring of oil and fuel, lubrication of machine and tools, hydraulic applications.

Type	50Hz 4p (1500rpm)				60Hz 4p (1800rpm)				Net weight 중량 kg
	Dis-charge Volume 유량 ℓ/min	Maximum pressure per Motor output 모터출력에 대한 최고압력 MPa			Dis-charge Volume 유량 ℓ/min	Maximum pressure per Motor output 모터출력에 대한 최고압력 MPa			
		400W	750W	1500W		400W	750W	1500W	
AMTP-204HA	6.3	2.15	3.0	3.0	7.5	1.6	3.0	3.0	3.6
AMTP-206HA	9.0	0.7	2.5	2.5	10.8	0.7	2.35	2.5	3.6
AMTP-208HA	12.6	0.45	2.3	2.5	15.1	0.4	1.75	2.5	3.7
AMTP-210HA	15.3	0.35	1.55	2.5	18.3	0.25	1.15	2.5	3.8
AMTP-212HA	18.0	0.2	1.35	2.0	21.6	-	0.85	2.0	4.0
AMTP-216HA	24.3	-	0.85	2.0	29.1	-	0.55	1.95	4.2
AMTP-220HA	29.7	-	0.55	1.55	35.6	-	0.35	1.4	4.5

Relief valve

Division 구분	Domain 압력 범위 MPa
1S	0 - 0.4
2S	0.4 - 0.8
3S	0.6 - 1.5
4S	1.2 - 3.0

• Applications 적용

Type of fluid 사용유체
: Oils
Viscosity 점도 (40°C 기준)
: 20 ~ 1000 cSt
Temperature 사용온도
: NBR 80°C
FKM 180°C

• Material 재질

Motor frame : Aluminum
Pump body : Cast iron
Port housing : Cast iron
Pump cover : Cast iron
Bearing : #6202zz, #6301zz
Shaft : Steel
Rotor : Powder steel
Oil-seal : NBR, FKM(Option)
Ø15×Ø35×7t
Ø17×Ø30×8t
Relief valve : Cast iron etc.

External dimensions 외형도

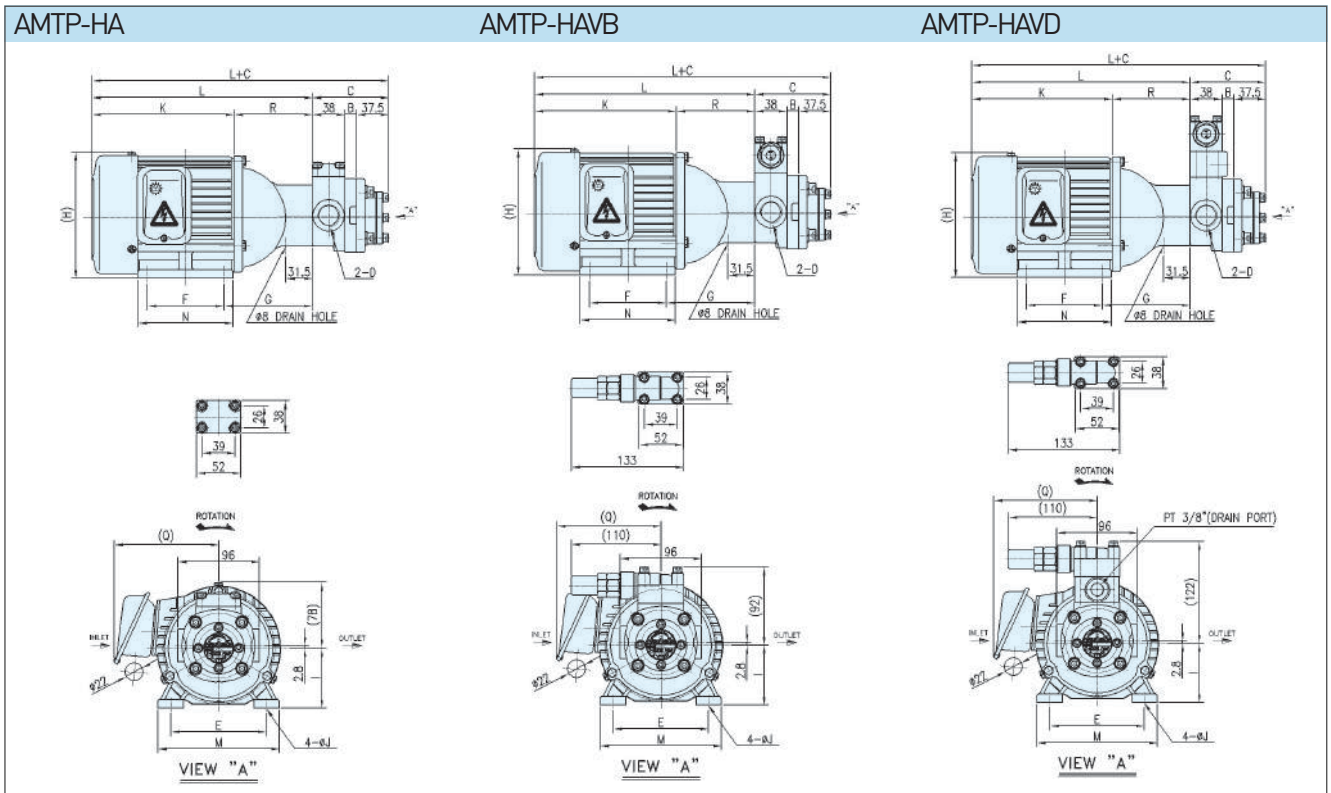

Type	E	F	G	H	I	J	K	L	M	N	Q	R
400W	112	90	104.5	150	71	10	167	259.5	143	120	125	92.5
750W	125	100	112.5	169	80	10	206	298.5	167	135	145	92.5
1500W	140	125	107.5	193	90	10	230	319	172	155	155	89

Type	B	C	D(Port dia) In/Outlet
AMTP-204 HA HAVB HAVD	7	82.5	PT 1/2"
AMTP-206 HA HAVB HAVD	10	85.5	
AMTP-208 HA HAVB HAVD	14	89.5	
AMTP-210 HA HAVB HAVD	17	92.5	PT 3/4"
AMTP-212 HA HAVB HAVD	20	95.5	
AMTP-216 HA HAVB HAVD	27	102.5	
AMTP-220 HA HAVB HAVD	33	108.5	

Type	Phase 3Ø, Poles 4p Free voltage					Net weight 중량 kg
	Motor Out-put 출력 kW	Motor speed 회전수 rpm	Fre- quency 주파수 Hz	Rated voltage 전압 V	Current 전류 A	
400W	0.4	1420	50	200	2.2	13.2
				380	1.3	
				415	1.1	
750W	0.75	1440	50	220	2.0	17.6
				380	1.2	
				440	1.0	
1500W	1.5	1710	60	200	3.5	23.6
				380	2.0	
				415	1.8	
	1.5	1730	60	220	3.2	
				380	1.9	
				440	1.7	
	1.5	1730	60	200	6.0	23.6
				380	3.5	
				415	3.3	
	1.5	1730	60	220	5.5	
				380	3.2	
				440	3.0	

◆ Enclosure class 보호등급 : IP44

◆ Insulation class 절연계급 : E

Motor T-ROTOR pumps

AMTP-HAVBF Series



AMTP - 750 - 206HAVBF 0.5

Motor out-put 모터출력	_____
Pump division 펌프구분	_____
Setting pressure 설정압력(MPa)	_____

- AMTP-HAVBF형 펌프는 자체에 Suction filter가 장착되어 있어 별도의 Filter장치가 필요하지 않으며 항상 청정한 유체를 흡입하여 토출하게 됨으로서 Rotor의 마모 및 손상을 방지할 수 있어 펌프의 수명을 연장할 수 있다.
- 자체에 장착된 Filter에는 교환 시기를 쉽게 식별할 수 있도록 게이지가 부착되어 있으며 Filter 종류는 Element식으로 세척하여 재사용 가능하다.
- 축봉장치용 Oil-seal을 이중으로 적용하여 내구성이 우수하다.
- 압력조절이 가능한 Relief valve가 부착되어 있어 Motor 및 Pump의 부하를 줄여 안전하게 사용할 수가 있다.
- 공작기계 및 각종 산업기계의 오일 및 연료이송, 윤활급유 등에 적합하다.
- AMTP-HAVBF pump itself has suction filter and always suck and discharge clear fluid. So it can improve the pump life by protecting abrasion and damage.
- The gauge is attached at pump to inform easily the exchange intervals of filter. (Element type)can use after.
- The double oil mechanical seal improves the pump endurance.
- This pump has a relief valve to control the pump pressure so that can avoid the load in motor and pump operation.
- This pump is used transferring of oil and fuel in industrial machine and lubrication of machine and tools.

Type	50Hz 4p (1500rpm)				60Hz 4p (1800rpm)				Net weight 중량 kg
	Dis-charge Volume 유량 Q/min	Maximum pressure per Motor output 모터출력에 대한 최고압력 MPa			Dis-charge Volume 유량 Q/min	Maximum pressure per Motor output 모터출력에 대한 최고압력 MPa			
		400W	750W	1500W		400W	750W	1500W	
AMTP-204HAVBF	6.3	1.0	1.0	1.0	7.5	1.0	1.0	1.0	7.2
AMTP-206HAVBF	9.0	0.7	1.0	1.0	10.8	0.7	1.0	1.0	7.2
AMTP-208HAVBF	12.6	0.45	1.0	1.0	15.1	0.4	1.0	1.0	7.3
AMTP-210HAVBF	15.3	0.35	1.0	1.0	18.3	0.25	1.0	1.0	7.4
AMTP-212HAVBF	18.0	0.20	1.0	1.0	21.6	-	0.85	1.0	7.6
AMTP-216HAVBF	24.3	-	0.85	1.0	29.1	-	0.55	1.0	7.8
AMTP-220HAVBF	29.7	-	0.55	1.0	35.6	-	0.35	1.0	8.1

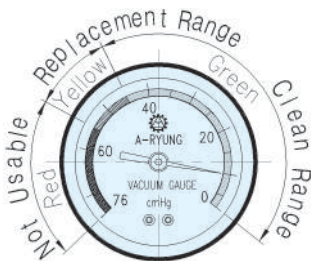

Filter의 교환 시는 진공게이지의 눈금으로 식별하여 적기에 교환 또는 세척 할것

- 적색 : 교환/세척
- 황색 : 주의
- 녹색 : 정상

The filter should be exchanged or cleaned on time by the vacuum gauge indication mark.

- Red : change or clean
- Yellow : Caution
- Green : Normal

External dimensions 외형도

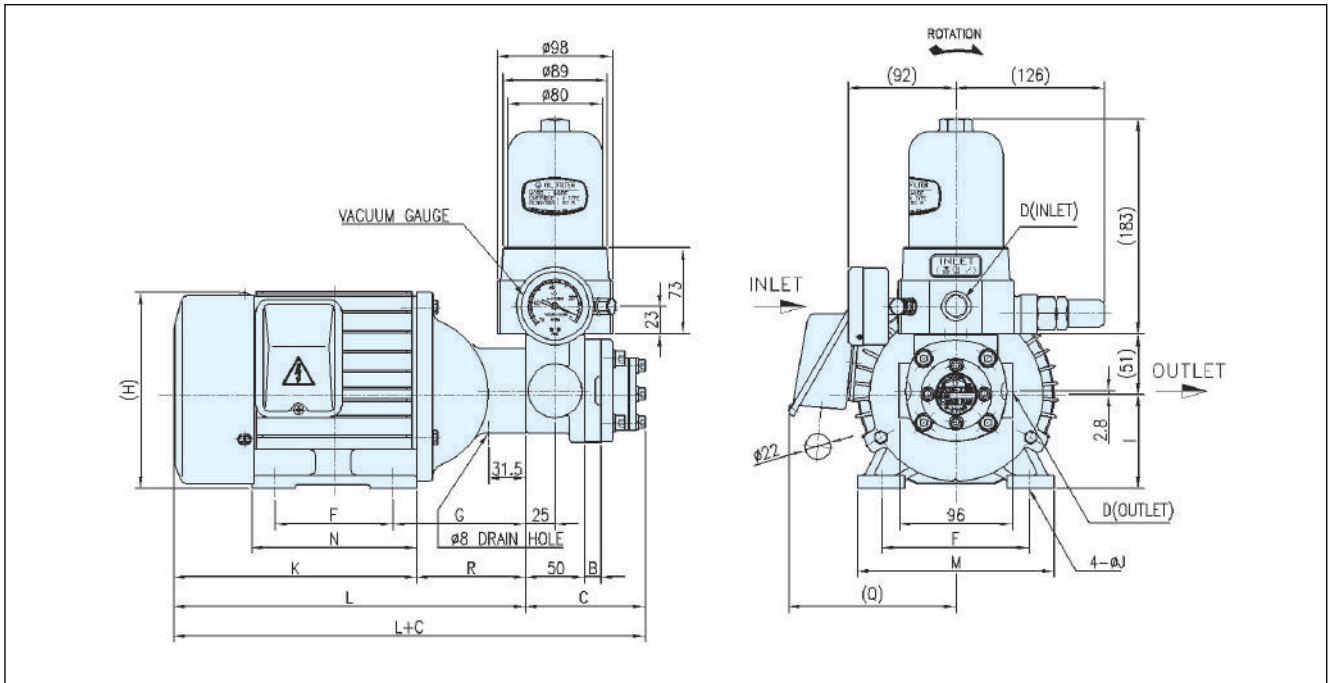

Type	E	F	G	H	I	J	K	L	M	N	Q	R
400W	112	90	104.5	150	71	10	167	259.5	143	120	125	92.5
750W	125	100	112.5	169	80	10	206	298.5	167	135	145	92.5
1500W	140	125	107.5	193	90	10	230	319	172	155	155	89

Type	Phase 3 Ø, Poles 4p Free voltage					Net weight 중량 kg
	Motor Out-put 출력 kW	Motor speed 회전수 rpm	Fre- quency 주파수 Hz	Rated voltage 전압 V	Current 전류 A	
400W	0.4	1420	50	200	2.2	13.2
				380	1.3	
				415	1.1	
750W	0.4	1710	60	220	2.0	17.6
				380	1.2	
				440	1.0	
1500W	0.75	1440	50	200	3.5	23.6
				380	2.0	
				415	1.8	
	0.75	1720	60	220	3.2	
				380	1.9	
				440	1.7	
1.5	1430	50	200	6.0		
			380	3.5		
			415	3.3		
1.5	1730	60	220	5.5		
			380	3.2		
			440	3.0		

Type	B	C	D[Port dia] In/Outlet
AMTP-204HAVBF	7	94.5	PT 1/2"
AMTP-206HAVBF	10	97.5	
AMTP-208HAVBF	14	101.5	
AMTP-210HAVBF	17	104.5	PT 3/4"
AMTP-212HAVBF	20	107.5	
AMTP-216HAVBF	27	114.5	PT 1"
AMTP-220HAVBF	33	120.5	

● Applications 적용

Type of fluid 사용유체
: Oils
Viscosity 점도 (40°C기준)
: 20 ~ 1000 cSt
Temperature 사용온도
: NBR 80°C
FKM 180°C

● Material 재질

Motor frame : Aluminum
Pump body : Cast iron
Port housing : Cast iron
Pump cover : Cast iron
Filter body & cover : Aluminum(ADC)
Filter : 100Mesh
Bearing : #6202zz, #6301zz
Shaft : Steel
Rotor : Powder steel
O1-seal : NBR, FKM(Option)
Ø15×Ø35×7t
Ø17×Ø30×8t

◆ Enclosure class 보호등급 : IP44

◆ Insulation class 절연계급 : E

Motor T-ROTOR pumps

AMTP - HA/HAVB Series

AMTP - 750 - 204HA / 208HAVB 0.5/0.8

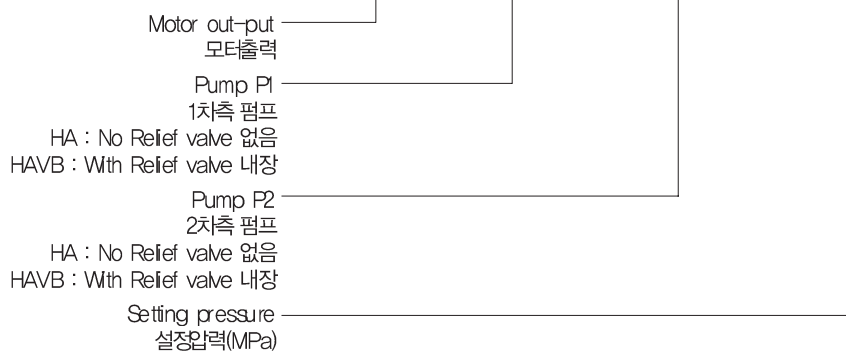

- AMTP-HA-HAVB형 펌프는 2개의 펌프를 1축 병렬식 일체형으로 Motor와 조합하여 경제적이고 또한 Compact하게 제작되었으며, Pump의 결합 및 분리가 간편하여 유지보수가 매우 용이하다.
- 축봉장치용 Oil-seal을 이중으로 적용하여 내구성이 우수하다.
- 열매체용으로 사용할 시는 불소재질의 Oil-seal을 적용하여 180°C이하의 고온에서도 사용이 가능하다.(선택사양)
- 압력조절이 가능한 Relief valve가 부착되어 있어 Motor 및 Pump의 부하를 줄여 안전하게 사용할 수가 있다.(선택사양)
- 공작기계 및 각종 산업기계의 오일 및 연료이송, 윤활급유, 유압장치 등에 적합하다.
- AMTP-HA-HAVB type have two pumps in a row and is combined motor. it is so compact and easy to assemble and dismantle between pump and motor.
- The double oil seal improves the endurance.
- For using in high temperature. This type can endure high temperature (below 180°C) applying the oil seal used the FKM material. (Option)
- This pump has a relief valve to control the pump pressure so that can avoid the load in motor and pump operation. (Option)
- This pump is used transferring of oil and fuel, lubrication of machine and tools, hydraulic applications.

Type	50Hz 4p (1500rpm)					60Hz 4p (1800rpm)					Net weight 중량 kg
	Discharge Volume 유량 ℓ/min		Maximum pressure per Motor output 모터출력에 대한 최고압력 MPa			Discharge Volume 유량 ℓ/min		Maximum pressure per Motor output 모터출력에 대한 최고압력 MPa			
	P1	P2	400W	750W	1500W	P1	P2	400W	750W	1500W	
AMTP-206HA/206HAVB	9.0	9.0	0.4	1.6	3.3	10.8	10.8	0.3	1.3	2.7	5.9
AMTP-208HA/206HAVB	12.6	9.0	0.3	1.2	2.7	15.1	10.8	0.3	1.0	2.3	6.0
AMTP-208HA/208HAVB	12.6	12.6	0.2	1.0	2.3	15.1	15.1	0.2	0.9	1.9	6.1
AMTP-210HA/208HAVB	15.3	12.6	0.2	0.8	2.0	18.3	15.1	-	0.6	1.7	6.2
AMTP-210HA/210HAVB	15.3	15.3	0.2	0.7	1.8	18.3	18.3	-	0.6	1.5	6.3
AMTP-212HA/208HAVB	18.0	12.6	-	0.7	1.6	21.6	15.1	-	0.6	1.3	6.4
AMTP-212HA/210HAVB	18.0	15.3	-	0.6	1.5	21.6	18.3	-	0.5	1.2	6.5
AMTP-212HA/212HAVB	18.0	18.0	-	0.5	1.1	21.6	21.6	-	0.5	1.1	6.7
AMTP-216HA/208HAVB	24.3	12.6	-	0.4	1.2	29.1	15.1	-	0.3	1.1	6.6
AMTP-216HA/210HAVB	24.3	15.3	-	0.4	1.2	29.1	18.3	-	0.3	1.0	6.7
AMTP-216HA/212HAVB	24.3	18.0	-	0.4	1.1	29.1	21.6	-	0.3	0.9	6.9
AMTP-216HA/216HAVB	24.3	24.3	-	0.3	0.9	29.1	29.1	-	0.2	0.8	7.1
AMTP-220HA/208HAVB	29.7	12.6	-	0.24	0.72	35.6	15.1	-	0.2	0.6	6.7
AMTP-220HA/210HAVB	29.7	15.3	-	0.24	0.6	35.6	18.3	-	0.2	0.5	6.8
AMTP-220HA/212HAVB	29.7	18.0	-	0.19	0.54	35.6	21.6	-	0.16	0.15	7.0
AMTP-220HA/216HAVB	29.7	24.3	-	0.17	0.48	35.6	29.1	-	0.14	0.4	7.2
AMTP-220HA/220HAVB	29.7	29.7	-	0.15	0.45	35.6	35.6	-	0.12	0.37	7.3

External dimensions 외형도

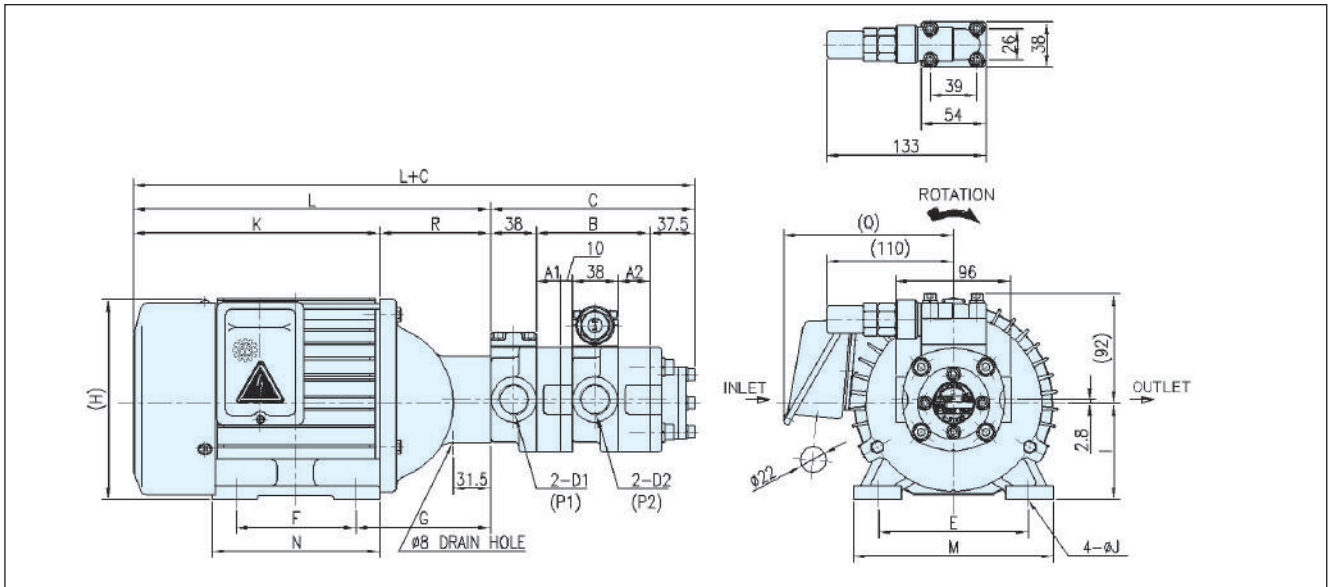

Type	E	F	G	H	I	J	K	L	M	N	Q	R
400W	112	90	104.5	150	71	10	167	259.5	143	120	125	92.5
750W	125	100	112.5	169	80	10	206	298.5	167	135	145	92.5
1500W	140	125	107.5	193	90	10	230	319	172	155	155	89

Type	Phase 3Ø, Poles 4p Free voltage					Net weight 중량 kg	
	Motor Out-put 출력 kW	Motor speed 회전수 rpm	Fre- quency 주파수 Hz	Rated voltage 전압 V	Current 전류 A		
400W	0.4	1420	50	200	2.2	13.2	
				380	1.3		
				415	1.1		
750W	0.75	1440	50	220	2.0		17.6
				380	1.2		
				440	1.0		
1500W	1.5	1720	60	200	3.5	23.6	
				380	2.0		
				415	1.8		
1500W	1.5	1430	50	220	3.2		23.6
				380	1.9		
				440	1.7		
1500W	1.5	1730	60	200	6.0	23.6	
				380	3.5		
				415	3.3		
1500W	1.5	1730	60	220	5.5		23.6
				380	3.2		
				440	3.0		

Type	B	C	A1	A2	In/Outlet	
					D1	D2
AMTP-206HA/206HAVB	68	143.5	10	10	PT 1/2"	PT 1/2"
AMTP-208HA/206HAVB	72	147.5	14	10	PT 1/2"	PT 1/2"
AMTP-208HA/208HAVB	76	151.5	14	14	PT 1/2"	PT 1/2"
AMTP-210HA/208HAVB	79	154.5	17	14	PT 3/4"	PT 1/2"
AMTP-210HA/210HAVB	82	157.5	17	17	PT 3/4"	PT 3/4"
AMTP-212HA/208HAVB	82	157.5	20	14	PT 3/4"	PT 1/2"
AMTP-212HA/210HAVB	85	160.5	20	17	PT 3/4"	PT 3/4"
AMTP-212HA/212HAVB	88	163.5	20	20	PT 3/4"	PT 3/4"
AMTP-216HA/208HAVB	89	164.5	27	14	PT 3/4"	PT 1/2"
AMTP-216HA/210HAVB	92	167.5	27	17	PT 3/4"	PT 3/4"
AMTP-216HA/212HAVB	95	170.5	27	20	PT 3/4"	PT 3/4"
AMTP-216HA/216HAVB	102	177.5	27	27	PT 3/4"	PT 3/4"
AMTP-220HA/208HAVB	95	170.5	33	14	PT 3/4"	PT 1/2"
AMTP-220HA/210HAVB	98	173.5	33	17	PT 3/4"	PT 3/4"
AMTP-220HA/212HAVB	101	176.5	33	20	PT 3/4"	PT 3/4"
AMTP-220HA/216HAVB	108	183.5	33	27	PT 3/4"	PT 3/4"
AMTP-220HA/220HAVB	114	189.5	33	33	PT 3/4"	PT 3/4"

◆ Enclosure class 보호등급 : IP44

◆ Insulation class 절연등급 : E

■ Applications 적용

Type of fluid 사용유체 : Oil
 Viscosity 점도(40°C 기준) : 20 ~ 1000 cSt
 Temperature 사용온도 : NBR 80°C
 FKM 180°C

■ Material 재질

Motor frame : Aluminum
 Pump body : Cast iron
 Port housing : Cast iron
 Pump cover : Cast iron
 Bearing : #6202zz, #6301zz
 Shaft : Steel
 Rotor : Powder steel
 Oil-seal : NBR, FKM(Option)
 Ø15×Ø35×7
 Ø17×Ø30×8
 Relief valve : Cast iron etc.

Motor T-ROTOR pumps

AMTP -750 -P4 Series



AMTP - 750 - P4 - 2520

Motor out-put
모터출력

Pump division
펌프구분

- AMTP-750-P4-2520형 펌프는 4개의 펌프를 1축 병렬식 일체형으로 Motor와 조합하여 경제적이고 또한 Compact하게 제작되었으며, Pump의 결합 및 분리가 간편하여 유지보수가 매우 용이하다.
- 공작기계 및 각종 산업기계의 오일 및 연료이송, 윤활급유, 유압장치 등에 적합하다.

- AMTP-750-P4-2520 type have four pumps in a row and is combined motor. it is so compact and easy to assemble and dismantle between pump and motor.

- This pump is used transferring of oil and fuel, lubrication of machine and tools, hydraulic applications.

Type	Motor Out-put 출력(w)	Frequency 주파수 Hz	Voltage 전압 V	Current 전류 A	Motor speed 회전수 rpm	Phase 상수 Ø	Poles 극수 P	In-let (PT)	Out-let (PT)
2520	750	50	200	3.7	1400	3	4	1/2"	1/2"
		60	200/220	3.4/3.3	1690/1700				

◆ Enclosure class 보호등급 : P44 ◆ Insulation class 절연계급 : E

External dimensions 외형도

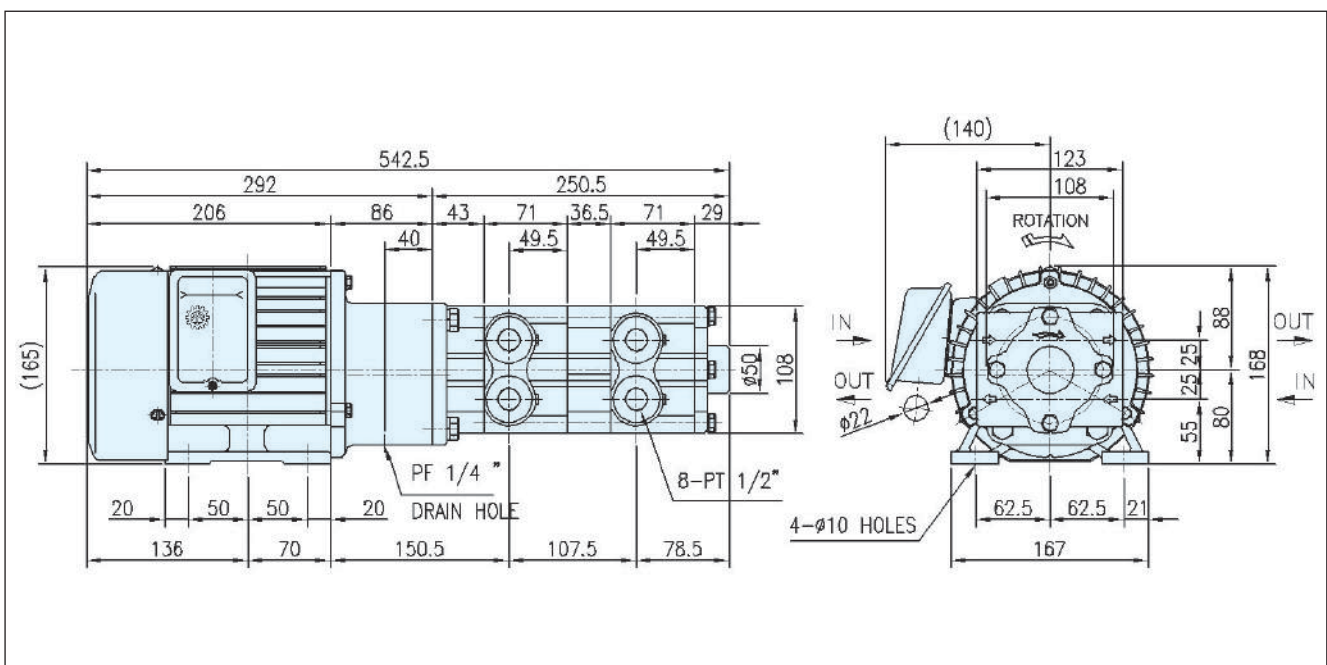

AMTP - 320LNVB Series



AMTP - 1500 - 320LNVB 0.5

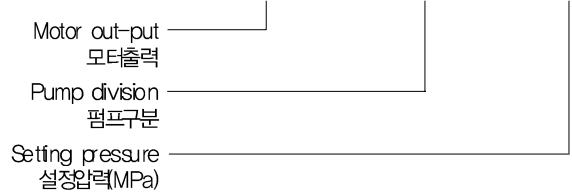

- AMTP-LN형 펌프는 저소음구조로 Motor와 Pump를 조합하여 Compact하게 설계되었으며, Motor와 Pump의 결합 및 분리가 간편하여 유지보수가 매우 용이하다.
- AMTP-LN type is low noisy structure pump, it is very compact, and it is easy to assemble and dismantle between pump and motor.
- 압력조절이 가능한 Relief valve가 부착되어 있어 Motor 및 Pump의 부하를 줄여 안전하게 사용할 수가 있다.
- This pump has a relief valve to control the pump pressure so that can avoid the load in motor and pump operation.
- 공작기계 스프트유 순환장치, 오일콘, 이송 유회장치 등에 적합하다.
- The pump is used the circulating system of spindle oil in machine, transferring lubrication system.

Type	PUMP				MOTOR				
	50Hz, 4p (1500rpm)		60Hz, 4p (1800rpm)		Phase 3Ø, Poles 4p				
	Discharge Volume 유량 ℓ/min	Max' Pressure 최고압력 MPa	Discharge Volume 유량 ℓ/min	Max' Pressure 최고압력 MPa	Motor Out-put 출력 kW	Motor speed 회전수 rpm	Frequency 주파수 Hz	Voltage 전압 V	Current 전류 A
AMTP-1500-320LNVB	39	0.75	46.8	0.75	1.5	1420	50	200	6.9
						1720	60	200	6.6
							60	220	6.6

◆ Enclosure class 보호등급 : IP44 ◆ Insulation class 절연계급 : E

External dimensions 외형도

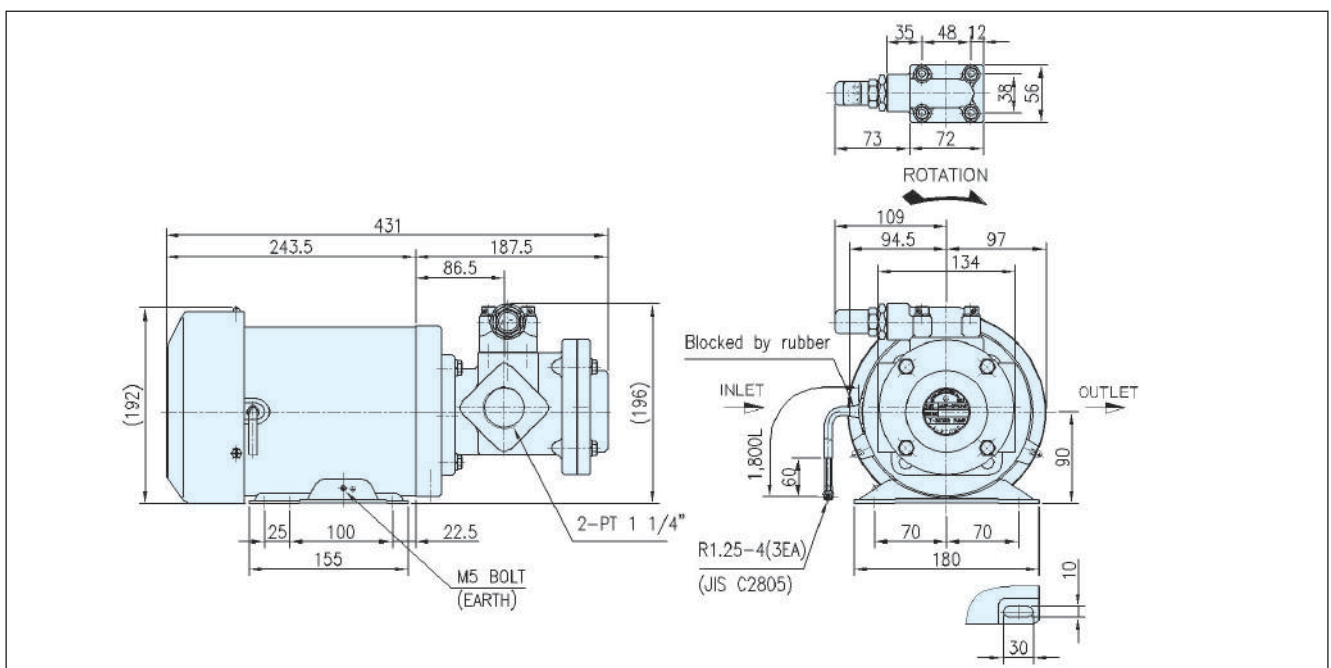

Motor T-ROTOR pumps

AMTP - LN Series



AMTP - 200 - 206LN VA

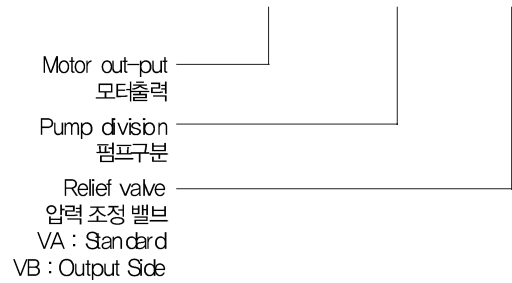

- AMTP-LN형 펌프는 저소음구조로 Motor와 Pump를 조합하여 Compact하게 설계되었으며, Motor와 Pump의 결합 및 분리가 간편하여 유지보수가 매우 용이하다.
- 압력조절이 가능한 Relief valve가 부착되어 있어 Motor 및 Pump의 부하를 줄여 안전하게 사용할 수가 있다.
- 공작기계 스피들유 순환장치, 오일론, 이송 유회장치 등에 적합하다.
- AMTP-LN type is low noisy structure pump, it is very compact, and it is easy to assemble and dismantle between pump and motor.
- This pump has a relief valve to control the pump pressure so that can avoid the load in motor and pump operation.
- The pump is used the circulating system of spindle oil in machine, transferring lubrication system.

Type	50Hz 4p (1500rpm)				60Hz 4p (1800rpm)			
	Dis-charge Volume 유량 Q/min	Maximum pressure per Motor output 모터출력에 대한 최고압력 MPa			Dis-charge Volume 유량 Q/min	Maximum pressure per Motor output 모터출력에 대한 최고압력 MPa		
		200W	400W	750W		200W	400W	750W
AMTP-204LN	6.3	0.4	0.6	0.6	7.5	0.4	0.6	0.6
AMTP-206LN	9.0	0.4	0.6	0.6	10.8	0.4	0.6	0.6
AMTP-208LN	12.6	0.4	0.6	0.6	15.1	0.4	0.6	0.6
AMTP-210LN	15.3	-	0.6	0.6	18.3	-	0.6	0.6
AMTP-212LN	18.0	-	0.6	0.6	21.6	-	0.6	0.6
AMTP-216LN	24.3	-	0.6	0.6	29.1	-	0.6	0.6
AMTP-220LN	29.7	-	-	0.6	35.6	-	-	0.6

LNVA Relief valve

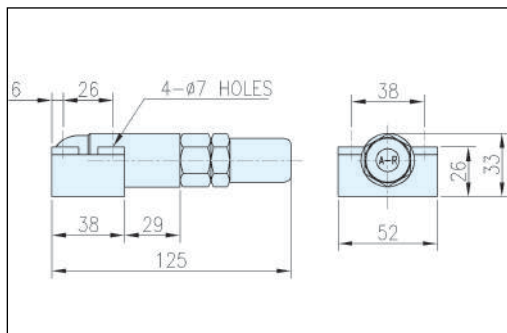

LNVB Relief valve

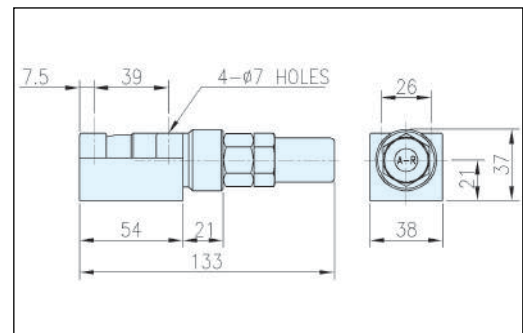

External dimensions 외형도

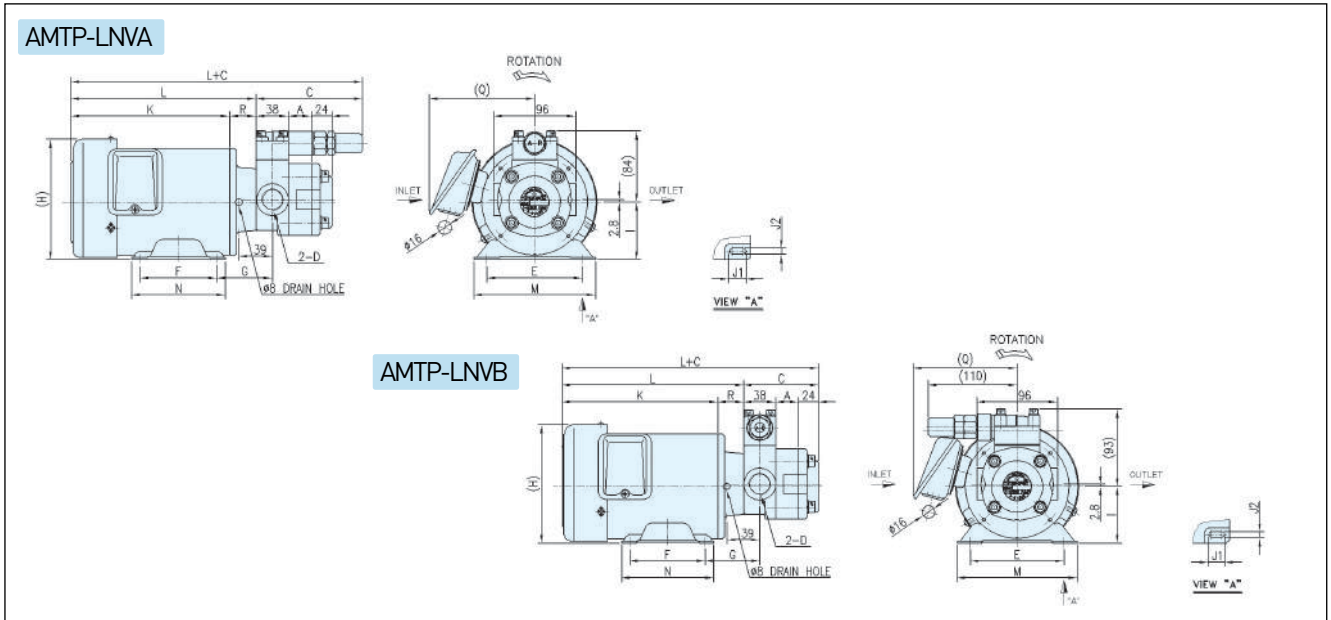

Type	E	F	G	H	I	J1	J2	K	L	M	N	Q	R
200W	110	80	67.5	135	64.5	15	7	181	212	136	106	122	31
400W	112	90	65	145	67.5	20	7	186	217	143	110	128	31
750W	125	100	72	170	80.5	30	10	226	257	169	124	140	31

Type	Phase 3 Ø, Poles 4p				
	Motor Output 출력 kW	Motor speed 회전수 rpm	Fre- quency 주파수 Hz	Rated voltage 전압 V	Current 전류 A
200W	0.2	1420	50	200	1.3
				380	0.8
	0.2	1720	60	200	1.15
				380	0.7
400W	0.4	1420	50	200	2.4
				380	1.5
	0.4	1720	60	200	2.3
				380	1.4
750W	0.75	1420	50	200	3.5
				380	2.1
	0.75	1720	60	200	3.4
				380	2.0

Type		A	C	D (Port dia)
				In/Outlet
AMTP-204	LNVA	7	125	PT 1/2"
	LNVB	7	69	
AMTP-206	LNVA	10	125	
	LNVB	10	72	
AMTP-208	LNVA	14	125	PT 3/4"
	LNVB	14	76	
AMTP-210	LNVA	17	125	
	LNVB	17	79	
AMTP-212	LNVA	20	125	
	LNVB	20	82	
AMTP-216	LNVA	27	125	
	LNVB	27	89	
AMTP-220	LNVA	33	125	
	LNVB	33	95	

◆ Enclosure class 보호등급 : P44

◆ Insulation class 절연계급 : E

■ Applications 적용

Type of fluid 사용유체 : Oils
 Viscosity 점도 (40°C기준) : 2 ~ 100 cSt
 Temperature 사용온도 : NBR 80°C

■ Material 재질

Motor frame : Steel
 Pump body : Cast iron
 Port housing : Cast iron
 Pump cover : Cast iron
 Shaft : Steel
 Rotor : Powder steel
 Oil-seal : NBR
 Ø19×Ø35×8t
 Relief valve : Cast iron etc.

Motor T-ROTOR pumps

AMTP-FAVB, HFVB Series



AMTP - 1500 - 321FA VB 0.5

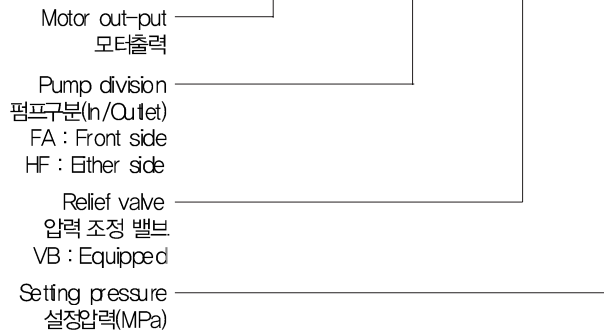

- AMTP-HFVB형 펌프는 Motor와 Pump를 조합하여 Compact 하게 제작되었으며, Motor와 Pump의 결합 및 분리가 간편하여 유지보수가 매우 용이하다.
- 열매체용으로 사용할 시는 불소재질의 Oil-seal을 적용하여 180 °C이하의 고온에서도 사용이 가능하다.
- 압력조절이 가능한 Relief valve가 부착되어 있어 Motor 및 Pump의 부하를 줄여 안전하게 사용할 수가 있다.
- 공작기계 및 각종 산업기계의 오일 및 연료이송, 윤활급유 등에 적합하다.
- AMTP-HFVB type is used combining motor with pump, it is very compact, and it is easy to fit and to separate the motor and pump part.
- This type can endure high temperature (below 180°C) applying the oil seal used the FKM material.
- This pump has a relief valve to control the pump pressure so that can avoid the load in motor and pump operation.
- This pump is used transferring of oil and fuel in machine and lubrication.

Type	50Hz 4p (1500rpm)		60Hz 4p (1800rpm)		50Hz 6p (1000rpm)		60Hz 6p (1200rpm)		Net wight 중량 kg				
	Dis-charge Volume 유량 ℓ /min	Maximum pressure 최고 압력 MPa		Dis-charge Volume 유량 ℓ /min	Maximum pressure 최고 압력 MPa		Dis-charge Volume 유량 ℓ /min	Maximum pressure 최고 압력 MPa					
		1.5kW	2.2kW		1.5kW	2.2kW		1.5kW		2.2kW	1.5kW	2.2kW	
AMTP-321FAVB	39	0.5	0.8	46.8	0.5	0.8	26	0.8	1.2	31.2	0.8	1.2	12.0
AMTP-341FAVB	78	0.3	0.4	93.6	0.3	0.4	52	0.4	0.6	62.4	0.4	0.6	12.5
AMTP-320HFVB	39	0.5	0.8	46.8	0.5	0.8	26	0.8	1.2	31.2	0.8	1.2	14.7
AMTP-340HFVB	78	0.3	0.4	93.6	0.3	0.4	52	0.4	0.6	62.4	0.4	0.6	15.5

Type	Motor Output 출력 kW	Fre- quency 주파수 Hz	Rated voltage 전압 V	Current 전류 A		Net Wigh 중량 kg 4p/6p
				Poles 극수 4p	Poles 극수 6p	
1500W	1.5	50/60	220/380	6.9/3.98	6.9/4.0	22.4
		60	220/440	6.9/3.45	6.9/3.5	/30.5
2200W	2.2	50/60	220/380	8.4/4.8	9.7/5.6	30.7
		60	220/440	8.4/4.2	9.7/4.8	/35.5

◆ Enclosure class 보호등급 : IP44 ◆ Insulation class 절연계급 : E

External dimensions 외형도

AMTP-FAVB

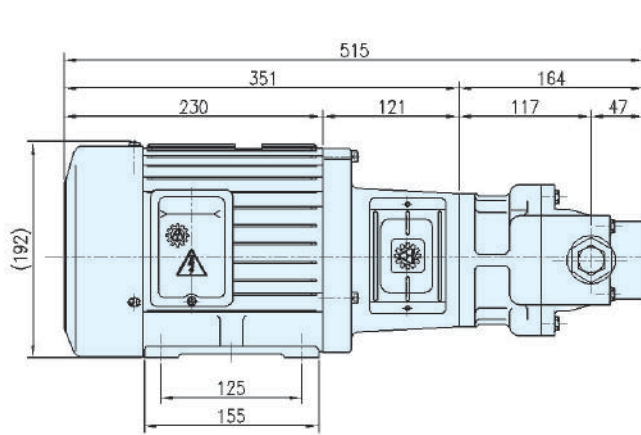

Type	D (Port dia)	
	Inlet	Outlet
AMTP-321FAVB	PT 1"	PT 1"

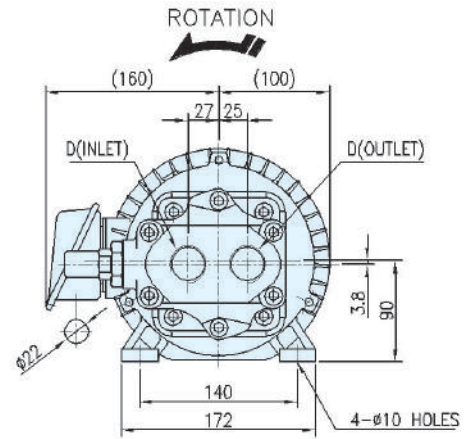

Type	D (Port dia)	
	Inlet	Outlet
AMTP-341FAVB	PT 1"	PT 1"

AMTP-HFVB

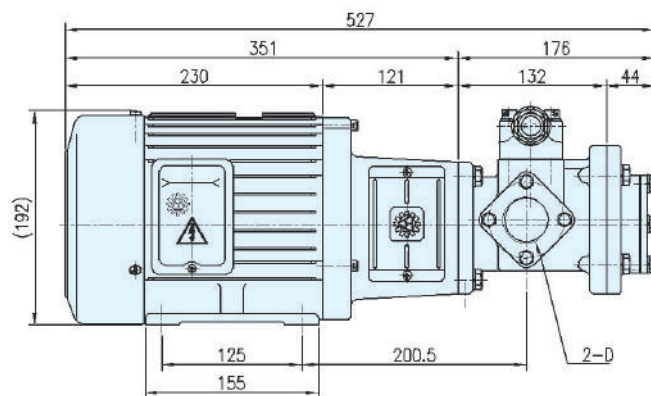

Type	D (Port dia)	
	Inlet	Outlet
AMTP-320HFVB	PT 1"	PT 1"

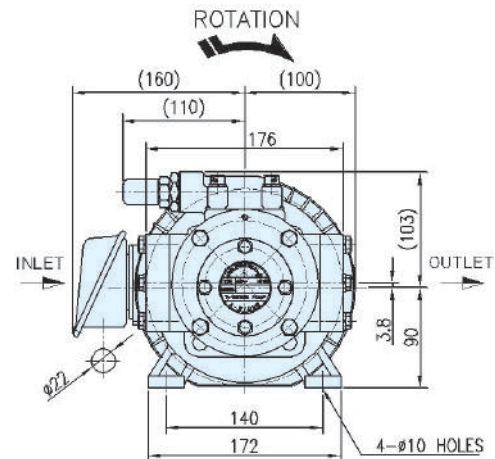

Type	D (Port dia)	
	Inlet	Outlet
AMTP-340HFVB	PT 1 1/4"	PT 1"

- In, Outlet - FAVB : Front side 흡입, 토출구 전면에 위치
- HFVB : Other side 좌우측에 위치
- 압력조절범위 : 0.2 ~ 1.0 MPa

- Applications 적용
 - Type of fluid 사용유체 : Oils
 - Viscosity 점도 (40°C기준) : 20 ~ 1000 cSt
 - Temperature 사용온도 : FKM 180°C

- Material 재질
 - Motor frame : Aluminum
 - Pump body : Cast iron
 - Port housing : Cast iron
 - Pump cover : Cast iron
 - Bearing : #6305zz, #63/22zz
 - Shaft : Steel
 - Rotor : Powder steel
 - Oil-seal : FKM Ø25×Ø40×8t

Motor T-ROTOR pumps

AMTP - CH(VB/VD) Series

저점도용

AMTP - 1500 - 216CH VB 2.0

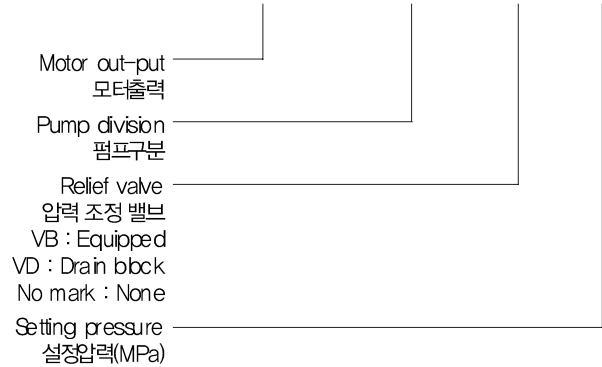

- 고압 Coolant용으로 설계되었으며, 공작기계 M.C.T 및 각종 산업 기계에 적합합니다.
- 흡입라인에 필터를 필히 부착하여 사용하십시오. (50 μ m 이하)
- Cyclone Filter system과 조합하여 사용이 가능합니다.
- AMTP-216CH(VD) series is designed for high pressure coolant usage. it is used M.C.T & various industrial machines.
- Make sure to attache the filter in suction part (less 50 μ m)
- It can be used to assemble with cyclone filter system.

Type	1500 rpm (50Hz, 4P)				1800 rpm (60Hz, 4P)			
	Discharge volume 유량 Q/min	Maximum pressure 최고압력 MPa			Discharge volume 유량 Q/min	Maximum pressure 최고압력(MPa)		
		1500W	2200W	3000W		1500W	2200W	3000W
216CH(VB,VD)-20	8	1.8	-	-	10.0	2.0	-	-
216CH(VB,VD)-25	12	-	2.3	-	16.0	-	2.5	-
216CH(VB,VD)-30	14	-	-	3.0	20.0	-	-	3.0

※노즐 구경에 따라 토출유량 & 토출압력이 변함. ※Discharge volume and Pressure is changed, According to Nozzle's diameter.

Motor Output 출력 W	Frequency 주파수 Hz	Voltage 전압 V	Current 전류 A	Motor speed 회전수 rpm	Phase 상수 Ø	Poles 극수 P
1500 W	50	200	6.9	1420	3	4
	60	220	6.6	1720		
2200 W	50	200	8.7	1420		
	60	220	8.4	1720		
3000 W	50	200	10.0	1420		
	60	220	10.0	1720		

◆ Enclosure class 보호등급 : IP44 ◆ Insulation class 절연등급 : E

■ Applications 적용

Type of fluid 사용유체
: Oils, Coolant
Viscosity 점도 (40°C 기준)
: 2 ~ 100 cSt
Temperature 사용온도
: NBR 80°C
FKM 180°C

■ Material 재질

Motor frame : Aluminum
Pump body : Cast iron
Port housing : Cast iron
Pump cover : Cast iron
Bearing : #6202zz, #6302zz

Shaft : Steel
Rotor : Powder steel
Oil-seal : NBR, FKM(Optional)
Ø15×Ø35×7t
Ø17×Ø30×8t

External dimensions 외형도

AMTP-1500-216CH - 20

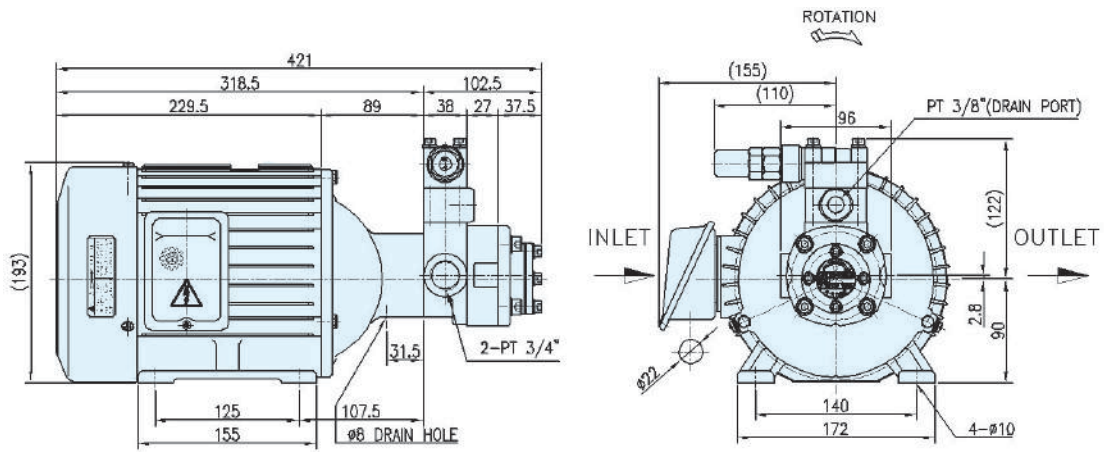

AMTP-2200-216CH - 25

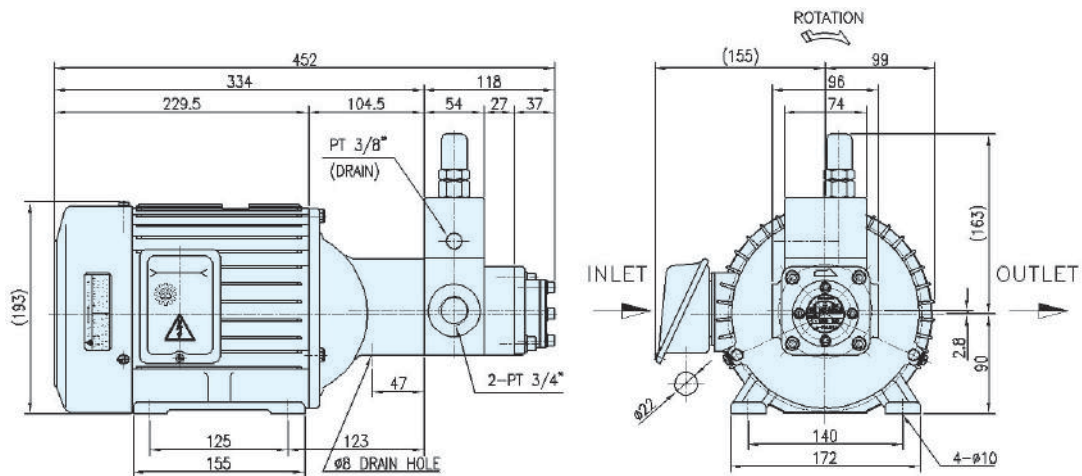

AMTP-3000-216CH - 30

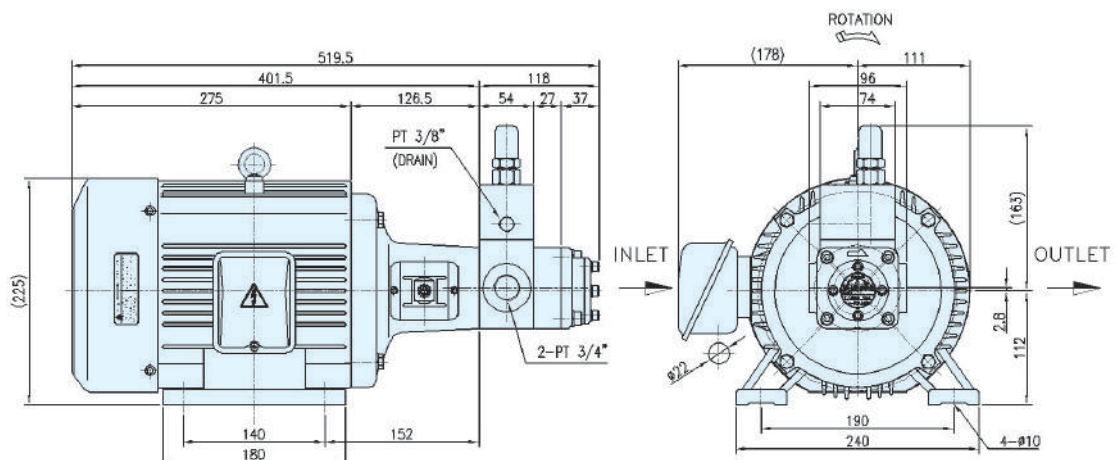

Motor T-ROTOR pumps

AFC - MSFVB Series



AFC - 200 - 12MSFVB - T10

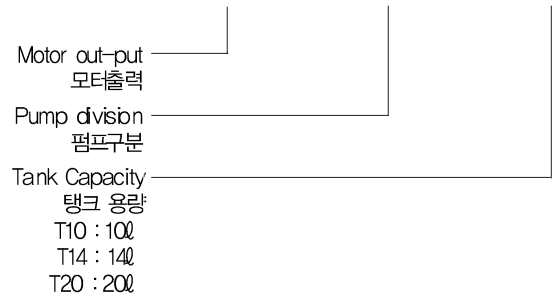

- 공냉식으로 헨 쿨러와 소형 순환펌프를 적용하여, 열교환 효율이 뛰어납니다.
- 또한 사용이 간편하고 외관이 콤팩트하여 공작기계 및 각종 산업 기계에 적합합니다.
- AFC series has an air-cooling system by fan cooler & small-sized circulating pump.
- It has high performance for heat exchange efficiency.
- It is compact & easy used for machine tools & various industrial machine.

Type	1500 rpm (50Hz, 4P)			1800 rpm (60Hz, 4P)			In-let (PT)	Out-let (PT)
	Discharge volume 유량 ℓ/min	Maximum pressure 최고압력 MPa		Discharge volume 유량 ℓ/min	Maximum pressure 최고압력 MPa			
		100W	200W		100W	200W		
12MSF(VB)	3.7	0.5	0.5	4.5	0.5	0.5	1/4"	1/4"
13MSF(VB)	6.7	-	0.5	8.1	-	0.5	3/8"	3/8"

Motor Output 출력 W	Frequency 주파수 Hz	Voltage 전압 V	Current 전류 A	Motor speed 회전수 rpm	Phase 상수 Ø	Poles 극수 P
100 W	50/60	200	0.65	1430	3	4
	60	220	0.6	1720		
200 W	50/60	200	1.3	1430	3	4
	60	220	1.1	1710		

◆ Enclosure class 보호등급 : IP44 ◆ Insulation class 절연계급 : E

Type	Tank Capacity ℓ	Fan Motor				
		Motor Output 출력 W	Phase 상수 Ø	Frequency 주파수 Hz	Voltage 전압 V	Current 전류 A
AFC-100-12MSFVB-T10	10	48	1	50/60	220-240	0.22
AFC-200-13MSFVB-T14	14					

- ◆ TANK 용량 및 장착위치는 주문자 요구에 의해 제작이 가능하다.
- ◆ Tank Capacity and mounting position can be made to order.

External dimensions 외형도

AFC -100-12MSFVB-T10

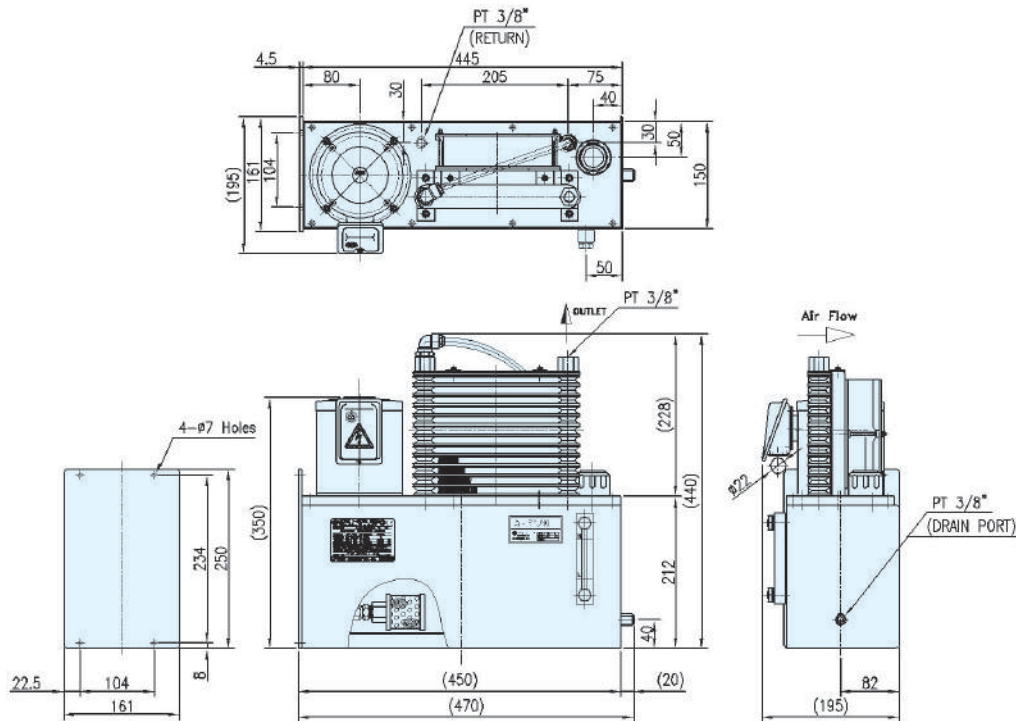

AFC -200-13MSFVB-T14

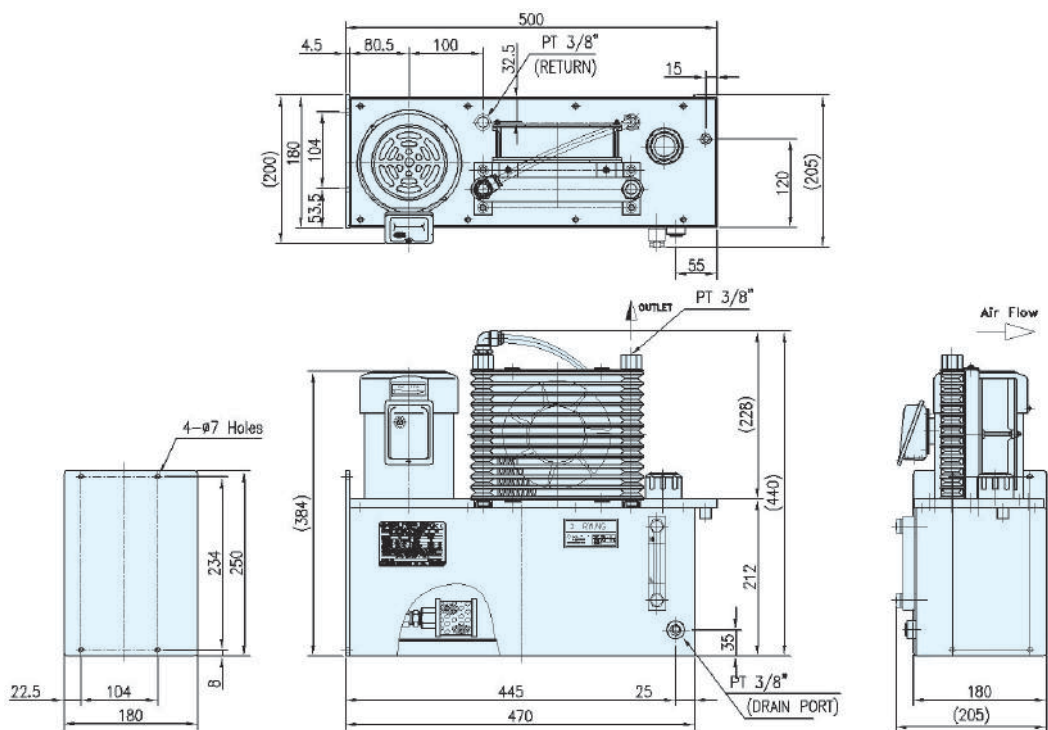

Motor T-ROTOR pumps

Fan Cooler

Model: AFC-010LT

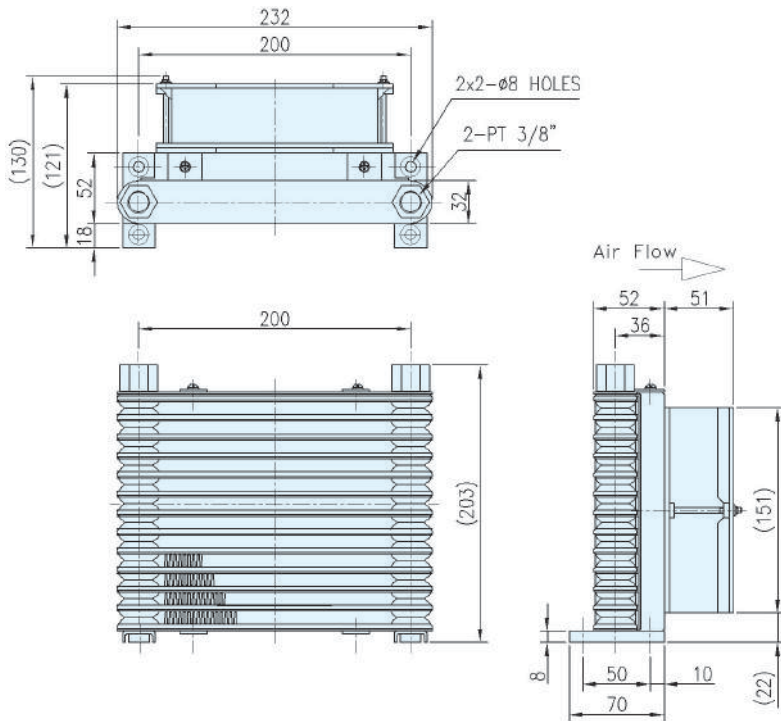

Motor output 모터출력	48 W
Voltage 전압	AC 220 V
Current 전류	0.22 A
Dis' Volume 사용 유량	10ℓ /min
Max' Pressure 최고 압력	15 bar

Model: AFC-100LT

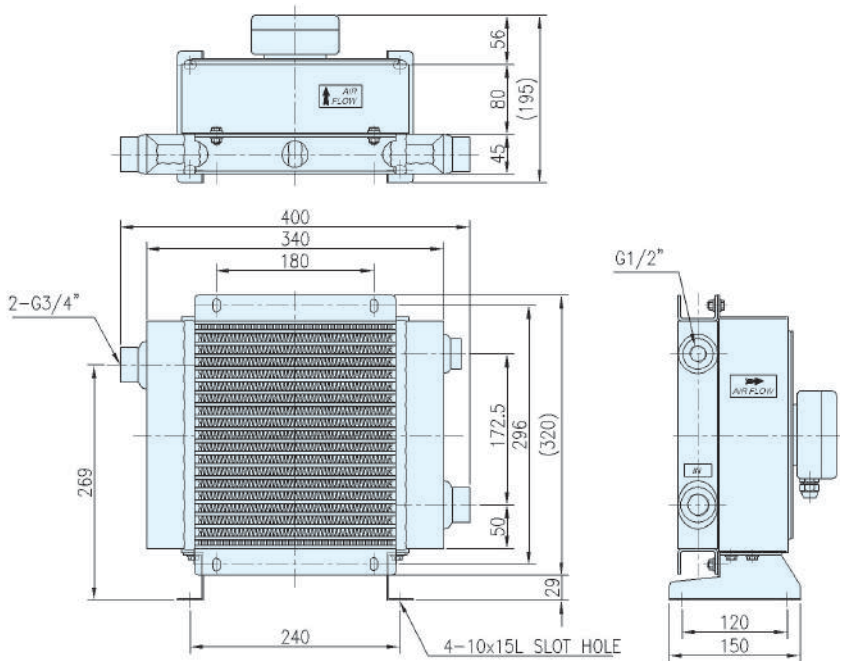

Motor output 모터출력	104 W
Voltage 전압	AC 220 V
Current 전류	0.48 A
Max' Dis' Volume 최대 사용 유량	100ℓ /min
Max' Pressure 최고 압력	35 bar

Terminal Connection

Single Voltage

Right Direction



Reverse Direction

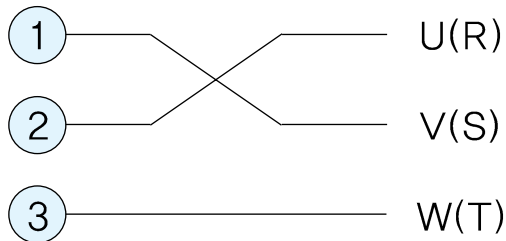

Dual Voltage

Low Voltage (200V, 220V)

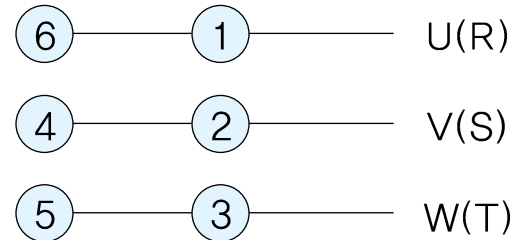

High Voltage (380V)

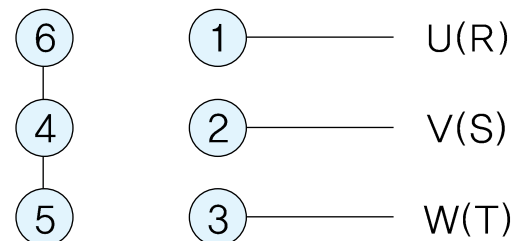

Double Voltage

Low Voltage (200V, 220V)

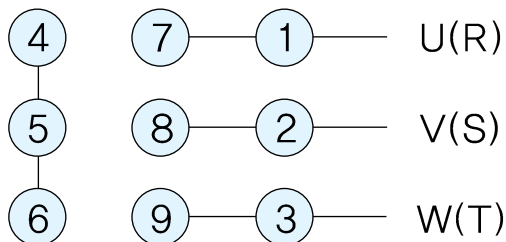

High Voltage (440V)

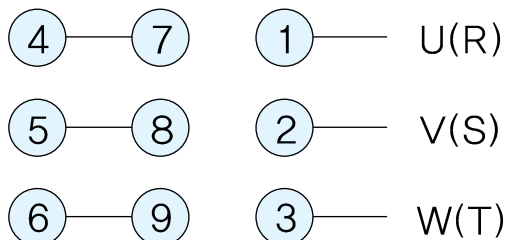

Free Voltage

Low Voltage (200V~240V)

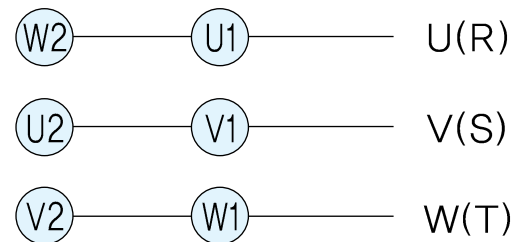

High Voltage (380V~440V)

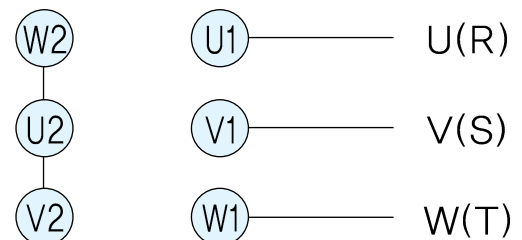

MEMO



▲ 2008년 5월 동탑산업훈장수훈

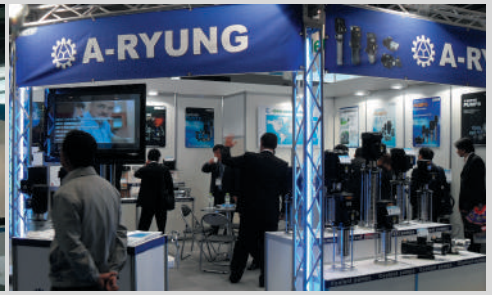

대한민국 대표 브랜드!!

공작기계 발전에는 늘 아룡이 함께합니다!!!

A-RYUNG The leading (pump) manufacturer in Korea.
A-RYUNG joins the development of Korean machine tools.



- | | | | |
|----------|---|----------|--|
| 1976. 5 | 아룡기공주 설립
Established as A-RYUNG Machinery Industry Co. Ltd. | 2003. 11 | 무역진흥 경제발전 공로 신자부장관 표창 수상 (No.54163)
Awarded "Prize of Trade Promotion and Industrial Development" from Ministry of Trade and Industry |
| 1980. 4 | 상공부지정 Oil pump 전문화 업체 지정(No.79-118)
Designated technical manufacturer of oil pump by the Ministry of Trade and Industry. | 2003. 12 | 수출공로 전라남도지사 표창 (No.1421)
Awarded "Prize of excellent Exporter" by Jeonnam Province. |
| 1982. 2 | 근대화 실천계획 승인업체지정 (중소기업진흥공단 No.8-208)
Designated as an "Approved Company of Systematization of Small & Medium Industry" by the Ministry of Trade and Industry. | 2004. 11 | 중국현지 법인 설립 "아룡기공(대련)유한공사"
Opened China office in Dalian named "A-Ryung Dalian Co. Ltd" |
| 1982. 5 | 우수중소기업 대통령표창 수상 (No. 54709)
Awarded the Korea Presidential Citation for an "Excellent Small & Medium Enterprise" | 2005. 12 | "공작기계발전" 공로 국무총리상 표창 (No.133740호)
Awarded "Honor of machine development" by The Prime Minister. |
| 1987. 9 | 국산기계개발 우수업체선정 부총리상 수상 (No.87-104호)
Awarded "Excellent company for domestic machine development" by the Deputy Prime Minister. | 2006. 12 | 무역의 날 기념 100만불 수출탑 수상
Prized "1 Million Tower of Export" celebrating National Trade Day |
| 1992. 12 | 자율세정 공로패 수상 (국세청)
Awarded "Self-Control company for National Tax" by National Tax Office. | 2007. 4 | 기업부설연구소 설립
Established "Research & Development Center" |
| 1993. 5 | 해외시장 수출 산업상 수상 (대한무역진흥공사)
Awarded an "Export Industry Prize for Overseas Market" by the Korea Trade Center. (KOTRA) | 2007. 9 | "MAIN-BIZ" (경영혁신형 중소기업인증)
Obtained "Main-Biz" (management innovation in small & medium Co) |
| 1996. 11 | "CE" 유럽안전규격 인증 (TUV Rheinland)
Authorized Conformity "EC" declaration by TUV Rheinland. | 2007. 10 | 싱글PPM 인증취득
Obtained "Certificate of Single PPM" |
| 1999. 6 | "EM" 기계류, 부품소재 우수품질규격 인증(한국기술표준원 No.1999-039호)
Obtaining Certification for EM Machinery, Spare parts by Korea Technique Standard Association. | 2007. 10 | "INNO-BIZ" (기술혁신형 중소기업인증 "AA등급")
Obtained "Inno-biz" (management innovation in small & medium Co) "AA Grade" |
| 1999. 11 | ISO 9001 품질경영시스템 인증 (KSA)
Obtaining the ISO 9001 Certification by the KSA-QA supported by IQ-NET. | 2008. 4 | 지망스런 중소기업인상 수상
CEO proud of small and medium sized enterprize award |
| 2000. 10 | "CSA-c-us" 미국 및 캐나다 안전규격 인증 (CSA INTERNATIONAL)
Obtained the "CSA-c-us" mark, American-Canadian Safety Standard by CSA INTERNATIONAL. | 2008. 5 | 동탑산업훈장 수상
awarded bronze tower of industry from ministry of public administration and security |
| 2000. 11 | 수출공로 신입자원부장관상 표창 (No.47956)
Awarded "The prize of Export-developing Company" by Ministry of Trade and Industry. | 2009. 2 | "NRTL" 북미 안전 인증 획득.
Obtained "NRTL" Certificate. |
| | | 2010.11 | 최저효율제 모터 인증 (0,75kw 이상)
Motor(more than 0,75kw) based on minimum energy efficiency Korean policy will be released in 2011. |

A-RYUNG MACHINERY IND. CO., LTD.



● **KOREA** Head office & Factory

#681-1, Daegok-ri, Keumseong-myun,
Damyang-gun, Jeonnam, Korea
전남 담양군 금성면 대곡리 681-1
TEL : ++82-61-380-2200
FAX : ++82-61-382-3094
URL : <http://www.aryung.co.kr>
Email : aryung@aryung.co.kr



● **CHINA** Branch office & Factory

#9 Tieshan East 3road Central Industrial District
Economic Development Zone Dalian City China
TEL : ++82-411-8734-6601~4
FAX : ++86-411-8734-6605
URL : <http://www.aryung.co.kr>
Email : a-ryung@163.com

● **JAPAN** Branch office

44 Shinmachi Ueda-shi Nagano-ken 386-1434 Japan
TEL : +81-268-71-5220, +81-268-38-4119
FAX : +81-268-38-4165
URL : <http://www.aryung.jp>
E-mail : k-nakazawa@aryung.jp

• 본 카탈로그는 사용자의 이해를 위한 제품의 개략적인 내용만을 담고 있습니다. 또한 제품의 품질개선을 위하여 내용은 예고 없이 변경될 수 있으므로 제품 선정시
본사 기술팀으로 문의 바랍니다.

• This catalog of products for users to understand overview contains information only. In addition to improving the quality of the product are
subject to change without notice in selecting products please contact our technical team.